

# DUGOUT PLAYERS BENCH

- MODEL #1176-06A 6 FT BENCH (45 lbs)
- MODEL #1176-08A 8 FT. BENCH (73 lbs)
- MODEL #1176-15A 15 FT. BENCH (110 lbs)
- MODEL #1176-21A 21 FT. BENCH (155 lbs)

Players "Dugout" Benches in a variety of sizes and Powder Coated Colors. Aluminum planks with 2"x2" aluminum angle frames.

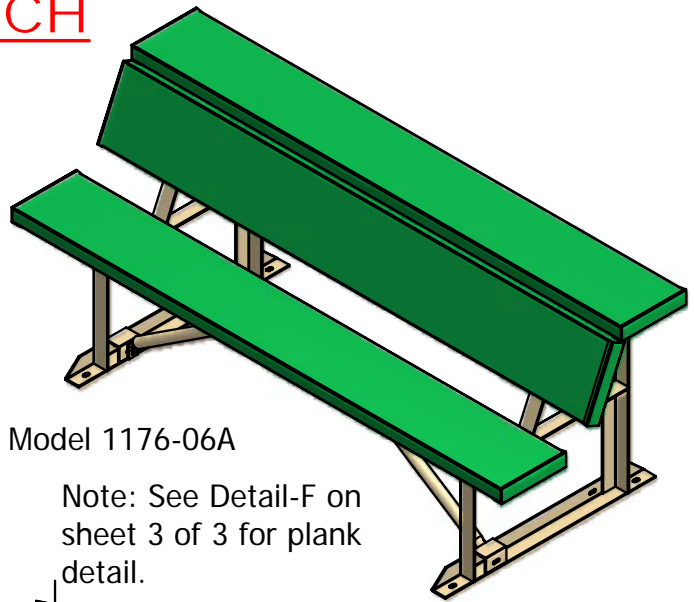

Model 1176-06A

Note: See Detail-F on sheet 3 of 3 for plank detail.

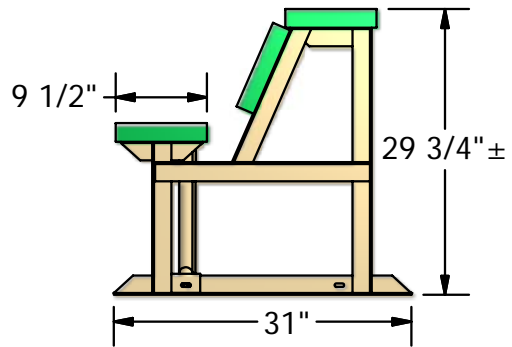
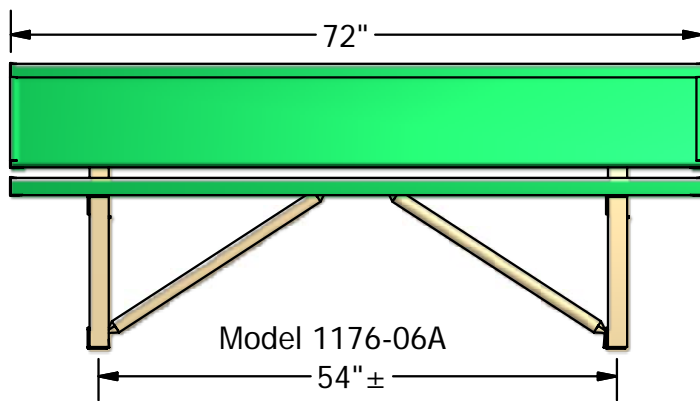

**General:** A durable aluminum bench especially suitable for dugouts or wherever a bench with a shelf is needed. Frames are fabricated from aluminum angle, and the planks are extruded aluminum. Benches are available in 6', 8', 15' and 21' lengths.

**Material:** All materials are selected for strength, durability and the ability to withstand years of exposure.

**Support Frames:** Fabricated with 2" x 2" aluminum angle and suitable for surface mounting and may be anchored to the surface. Two frames are required for the 6' and 8' benches; three frames for the 15' bench; and four frames for the 21' bench.

**Seat Planks:** Extruded 2" x 10" aluminum mounted to frame with friction-type aluminum mounting clips.

**Finish:** All welds are ground smooth. Aluminum plank finish is clear anodized. All hardware is zinc-plated for long, rust free service.

**Warranty Period:** 3 Years

	Date: 7-17-08	<b>SPECIFICATION/INSTALLATION INSTRUCTIONS</b>
	Rev: A022511	
	Drawn: AMC	MODEL NO.
	Sheet: 1 of 3	<b>1176-06, -08, -15, -21</b>

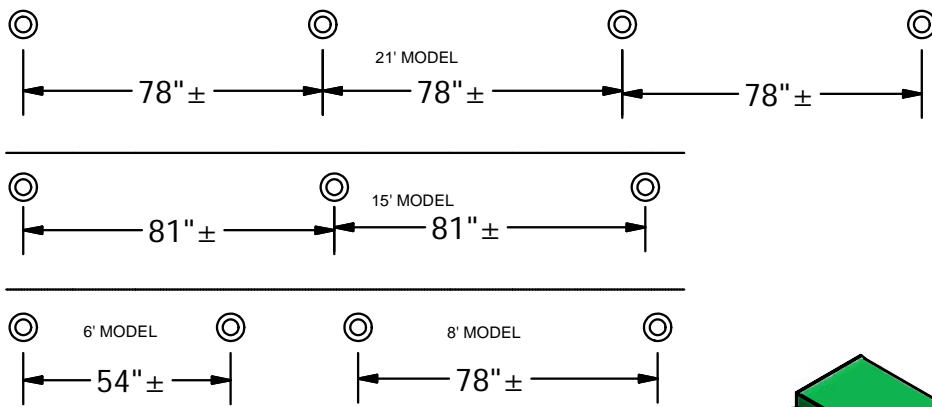

**Spacing between frames  
(Detail "A")**

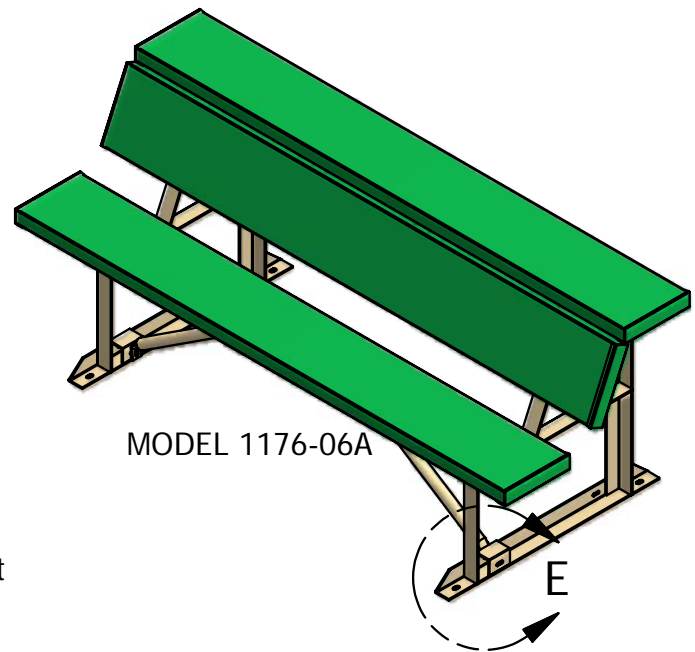
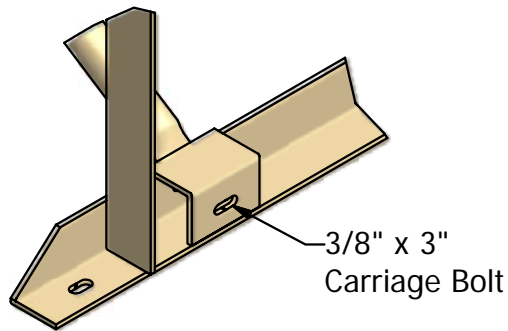

**ALUMINUM INSTALLATION INSTRUCTIONS:**

1. Determine the model of bench to be installed. Use Detail A to determine the distance between frames.
2. Assemble and align end caps on aluminum planks. Install self-drilling, self-tapping Tek screws on end caps.
3. Assemble extruded clips on seat supports with 5/16" x 1" carriage bolts, washers and nuts provided. (See Detail A page 3) Finger-tighten bolts to where nylon begins in nut. Rotate clips 90° to the frame.
4. Lay aluminum plank over plank clips. Rotate plank clips so the grooves lock down on the plank. Tighten bolts to where nylon begins in nut. The first seat support will be approximately 9" from center of support to end of plank. Assemble other seat supports to plank in same manner.
5. Install bench braces to frames using 3/8" x 3" carriage bolt. (See Detail above). Insert bolt through frame, holding bolt in place assemble one end of brace over bolt and install 3/8" lock nut. Do not tighten nut at this time, just install until finger tight.
6. Attach the other end of the brace pipe to the bottom of the aluminum plank with two plank clips with a 5/16" x 1-1/4" carriage bolt and nut. Repeat for all subsequent braces.
7. Plumb braces to planks and tighten all hardware securely so the clips are firmly in contact with the mounting surface(s).

	Date: 7-17-08	<b>SPECIFICATION/INSTALLATION INSTRUCTIONS</b>
	Rev: A120511	
	Drawn: AMC	MODEL NO.
	Sheet: 2 of 3	<b>1176-06, -08, -15, -21</b>

PLANK ATTACHMENT TO FRAME  
DETAIL - C

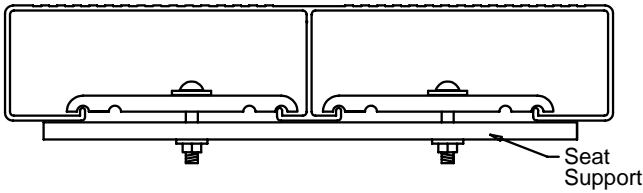

BRACE ATTACHMENT TO SEAT  
DETAIL - B

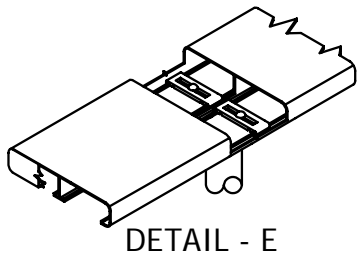
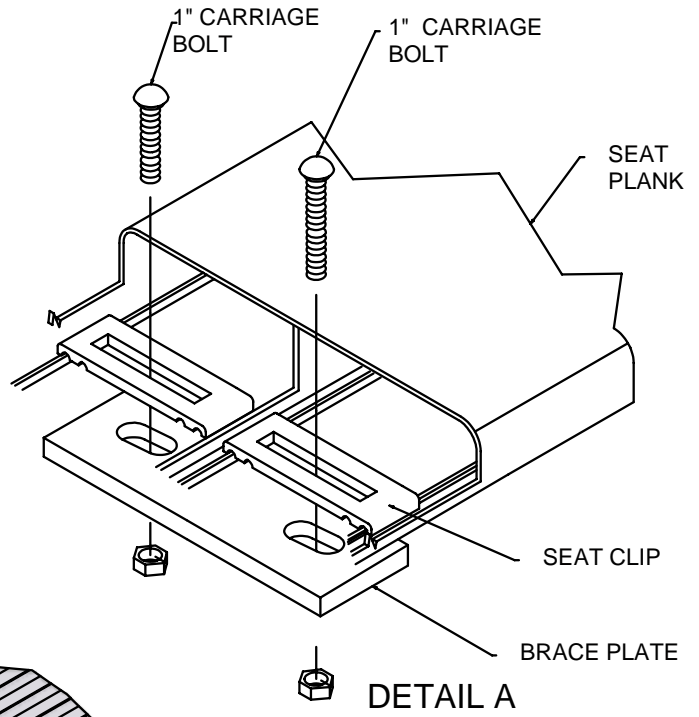
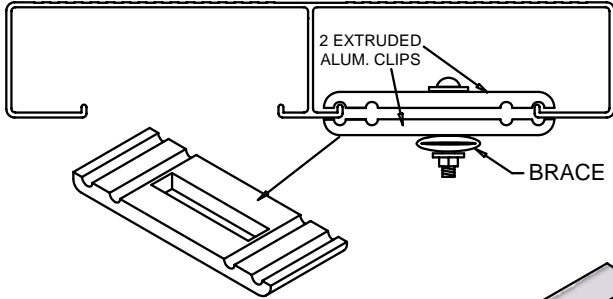

DETAIL - E

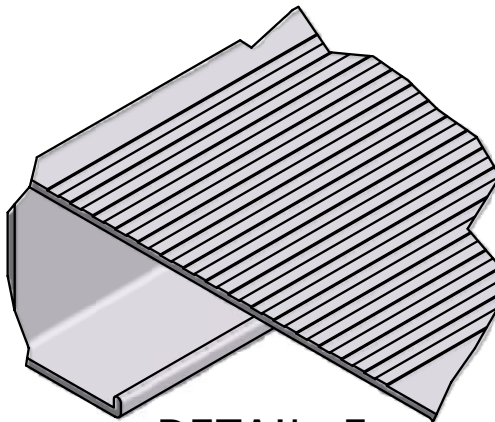

DETAIL F

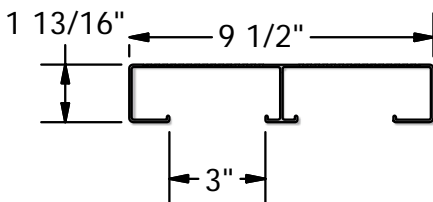
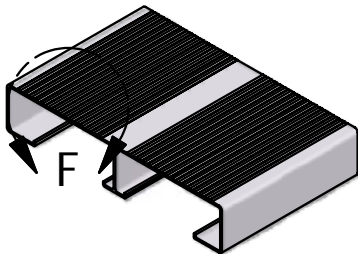

ALUMINUM PLANK

ALUMINUM DUGOUT PLAYERS BENCH				
Material List	-06	-08	-15	-21
Length of Bench	6'	8'	15'	21'
Bench Frame	2	2	3	4
Brace Pipe 32"	2	2	4	6
Anodized Aluminum Plank	3	3	3	3
Aluminum End Cap	6	6	6	6
#10 x 3/4" Tek Screw	12	12	12	12
Aluminum Plank Clip	16	16	26	36
5/16" x 1" Carriage Bolt	12	12	18	24
5/16" x 1-1/4" Carriage Bolt	2	2	4	6
5/16" Lock Nut - Nylock	14	14	21	30
5/16" Fender Washer	1	1	2	3
5/16" Flat Washer	14	14	21	30
3/8" x 3" Carriage Bolt	2	2	3	4
3/8" Flat Washer	4	4	6	8
3/8" Lock Nut - Nylock	2	2	3	4



Date: 7-17-08  
 Rev: A120511  
 Drawn: AMC  
 Sheet: 3 of 3

**SPECIFICATION/INSTALLATION INSTRUCTIONS**  
 ALUMINUM "DUGOUT" PLAYERS BENCH  
 MODEL NO.  
**1176-06, -08, -15, -21**

Pick Ticket  
 Fabrication to provide frames  
 Shipping to pull hardware, Plank and Braces.  
 If shortages occur notify office.

ALUMINUM DUGOUT PLAYERS BENCH

Maerial List	-06	-08	-15	-21
Length of Bench	6'	8'	15'	21'
Bench Frame	2	2	3	4
Brace Pipe 32"	2	2	4	6
Anodized Aluminum Plank	3	3	3	3
Aluminum End Cap	6	6	6	6
#10 x 3/4" Tek Screw	12	12	12	12
Aluminum Plank Clip	16	16	26	36
5/16" x 1" Carriage Bolt	12	12	18	24
5/16" x 1-1/4" Carriage Bolt	2	2	4	6
5/16" Lock Nut - Nylock	14	14	21	30
5/16" Fender Washer	1	1	2	3
5/16" Flat Washer	14	14	21	30
3/8" x 3" Carriage Bolt	2	2	3	4
3/8" Flat Waher	4	4	6	8
3/8" Lock Nut - Nylock	2	2	3	4

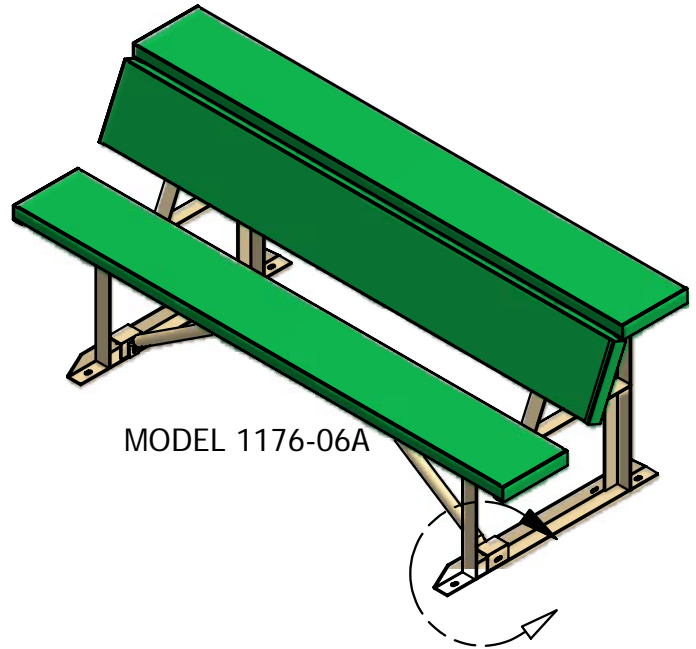

MODEL 1176-06A