

Scorers Table

1178-06A
 1178-08A
 1178-06RCA
 1178-08RCA

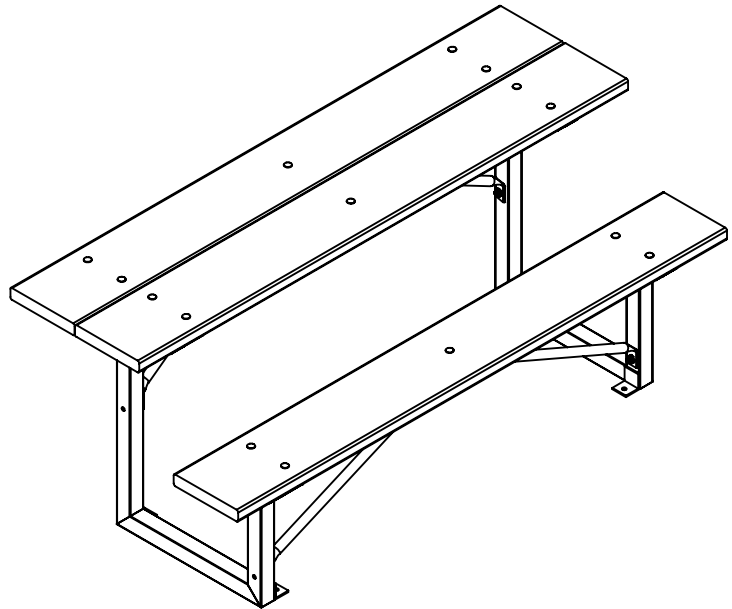

General: A durable scores table for any sporting event. Frames are fabricated from 2x2 steel square tube, & the planks are available in Extruded Aluminum or Recycled Plastic. Tables are available in 6' & 8' lengths.

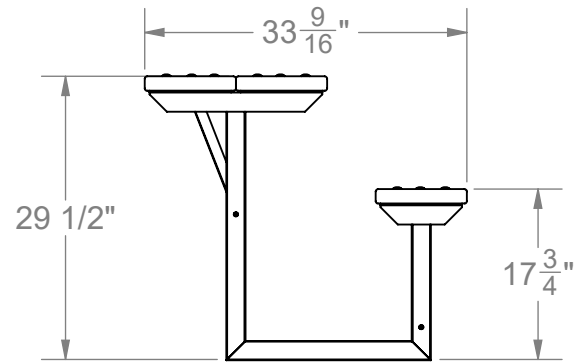
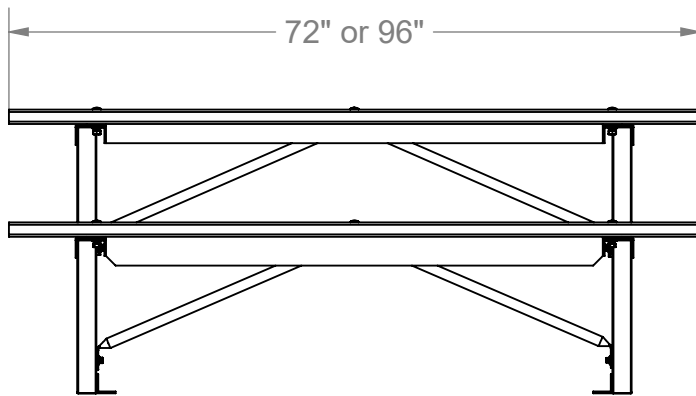

SPECIFICATIONS:

MATERIAL: All materials are selected for strength, durability and the ability to withstand years of exposure.

SUPPORT FRAMES: Fabricated with 2" x 2" steel tube & 2" x 3" steel angle, offering a right & left frame.

SEAT PLANKS: Extruded 2" x 10" aluminum mounted to frame with friction-type aluminum mounting clips, or recycled plastic 2" x 10" planks mounted to splines.

FINISH: Frames are powder coated. Aluminum plank finish is clear anodized. All hardware is zinc-plated for long, rust free service.

WARRANTY PERIOD: 3 Years

(Note: Bench must be anchored. Anchoring hardware not included.)



SITE FURNISHINGS

SCALE: N.T.S.	SPECIFICATION / INSTALLATION INSTRUCTIONS
DATE: 7/9/2020	
DRAWN: JBN	Scorers Table
REV: A	MODEL 1178
SHEET: 1 of 3	

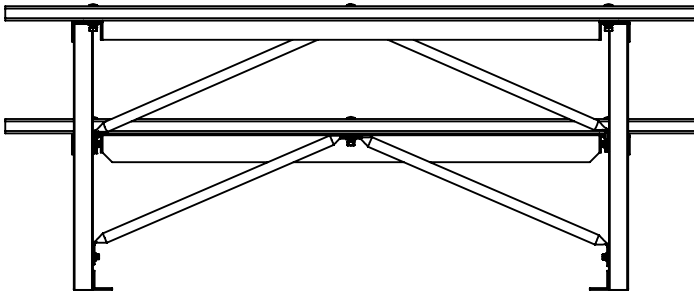

Model 1178 RCA

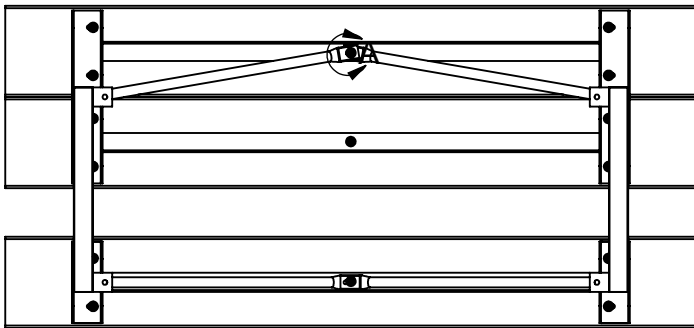

Length of Bench	6'	8'
Table Frame	2	2
1" Tube Brace	4	4
Steel Seat Spline	1	1
Aluminium Table Spline	2	2
5/16" x 1-1/2" Bolt	4	4
5/16" x 2-1/2" Carriage Bolt	13	13
5/16" x 3" Carriage Bolt	2	2
5/16" Flat Washer	19	19
5/16" Split Washer	19	19
5/16" Nut	15	15

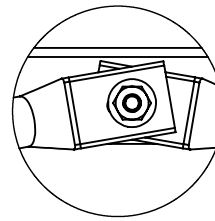

DETAIL A
SCALE 1 : 4

INSTALLATION INSTRUCTIONS for RECYCLED PLASTIC BENCH:

1. Insert 5/16" x 2-1/2" Carriage Bolts into 3 planks using the pre-drilled holes provided so the bolt heads are seated. Note: On the top-front and seat plank you will have to use the 5/16" x 3" Carriage Bolts in the center hole. This will be used for the Spline & Brace Pipe installation later.
2. Lay the 2 table planks upside down on a hard clean surface (to keep bolts seated) with the bolt threads facing up. Place planks next to each other and line up ends. Note: Plank with 5/16" x 3" Bolt will have to be used as the middle plank.
3. Place the 55-1/4" or 79-1/2" Table Spline over the exposed bolt threads.
Note: Align all angle supports in the same direction.
4. Stand end frame over bolt threads with angle facing in.
5. Attach end frames to planks with 5/16" Flat Washer, Split Washer & Nut. Attach seat plank in same manner.
6. Attach tube brace to center 5/16" x 3" Carriage Bolts using 5/16" Split Washer, Flat Washer & Nut.
7. Attach other end of brace to the end frame with 5/16" x 1-1/2" Hex Head Bolt, split washer & nut.
Only finger tight
8. Tighten all bolts. Note: Tighten all the bolts that are seated in the RCP planks slowly so you will NOT strip out the shoulder of the bolt...



SITE FURNISHINGS

SCALE: N.T.S.	SPECIFICATION / INSTALLATION INSTRUCTIONS Scorers Table
DATE: 7/9/2020	
DRAWN: JBN	
REV: A	
SHEET: 2 of 3	MODEL 1178

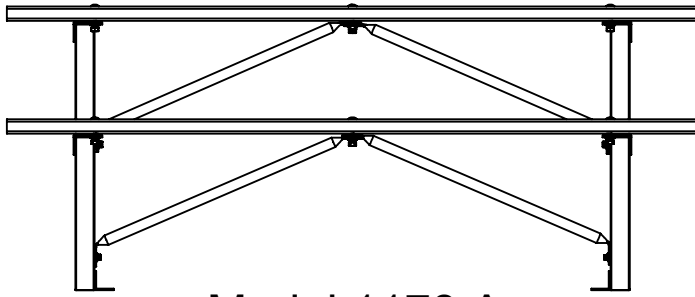

Model 1178 A

Length of Bench	6'	8'
Bench Frame	2	2
Brace Tube	2	2
Anodized Aluminum Plank	3	3
Aluminium End Cap	6	6
Aluminium Plank Clip	16	16
#10 x 3/4" Tek Screw	12	12
5/16" x 1" Carriage Bolt	12	12
5/16" x 2" Carriage Bolt	2	2
5/16" Flat Washer	18	18
5/16" Nylock Nut	14	14
5/16" x 1-1/2" Hex Head Bolt	4	4
5/16" Split Washer	4	4

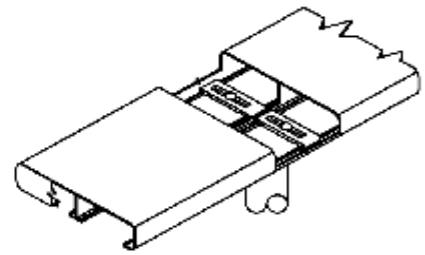
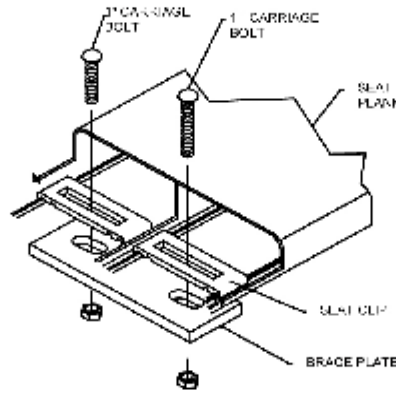
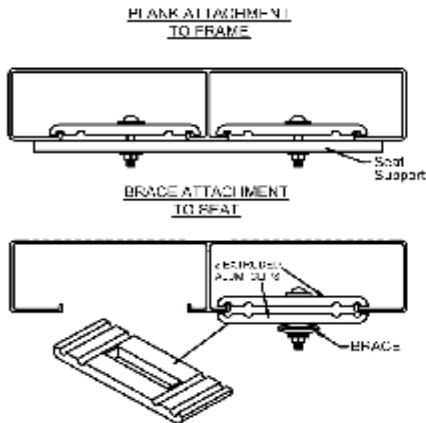

INSTALLATION INSTRUCTIONS for ALUMINUM BENCH:

1. Determine the model of table to be installed.
2. Assemble & Align End Caps on Aluminum Planks. Install self-drilling, self-tapping Tek Screws on end caps.
3. Assemble extruded clips on seat supports with 5/16" x 1" carriage bolts, washers and nuts provided. Finger-tighten bolts to where nylon begins in nut. Rotate clips 90Deg. to the frame.
4. Lay aluminum planks over plank clips. Rotate plank clips so the grooves lock down on the plank.
5. Install bench braces to frames using 5/16" x 2" Hex Bolt split washer and flat washer. Do not tighten bolt at this time, just install until finger tight.
6. Attach the other end of the brace pipe to the bottom of the aluminum plank with two plank clips with a 5/16" x 2" Carriage Bolt and Nut. Repeat for all subsequent braces.
7. Plumb braces to planks and tighten all hardware securely so the clips are firmly in contact with the mounting surfaces.



SITE FURNISHINGS

SCALE: N.T.S.	SPECIFICATION / INSTALLATION INSTRUCTIONS Scorers Table
DATE: 7/9/2020	
DRAWN: JBN	
REV: A	
SHEET: 3 of 3	MODEL 1178