

40' PERPENDICULAR ARCH BACKSTOP

MODEL #1212-00 - ARCH BACKSTOP 15'6"H x 15'6"D x 40'W (2,250 LBS)

OVERHEAD and BASE Arches: 2-7/8" O.D. galvanized steel.

SPECIFICATIONS:

Vertical Ribs: 2-3/8" O.D. galvanized steel. Ribs shall be formed to a smooth continuous radius throughout the entire length of each rib.

Flattened Sleeves: 1-7/8" O.D. galvanized steel, factory flattened and punched.

Horizontal Stiffeners: 1-3/8" O.D. galvanized steel, secured between vertical ribs with 2-way split clamps (galvanized), zinc plated 3/8" x 1-1/4" carriage bolts split washers and hex nuts. Where stiffeners connect to outside ribs, 3/4" wide galvanized steel brace bands shall be used along with 3/8" x 1" carriage bolts split washers and hex nuts. Any exposed threads to be destroyed by Installer.

Main Footing Anchors: 2-7/8" O.D. galvanized steel, welded sleeves that fit into BASE and OVERHEAD arch ends (2-3/8" O.D. galvanized steel). Footing anchors shall extend 3 feet into footings and shall be welded at the bottom with one piece of 6" long angle (2" x 2" x 3/16") steel, to form an anchor in the concrete footing.

Anchor Bolts: 5/8" x 12" foundation bolts, extending throughout BASE arch and shall be evenly spaced between vertical ribs. Any exposed threads to be destroyed by Installer.

Tension Bars: 3/4" galvanized and shall be secured with galvanized tension bands spaced 18 inches on center and bolted with 5/16" x 1" zinc-plated carriage bolts lock washers and hex nuts. Tension bars shall be installed along inside overhead arch.

Chain Link Fabric: Fabric shall be 9-gauge on all models except top (third) course shall be 11-gauge. It shall be installed horizontally in single lengths to outside of backstop using 12-gauge galvanized wire ties every 18 inches along vertical ribs. Edges shall be over-lapped a minimum of 1" to 2" and tied together with 9-gauge, #3 galvanized hog rings every 6 inches along seams. Fabric shall be pulled tight around curvature of backstop and shall be cut and trimmed in a neat and professional manner. Where wire is cut, exposed barbs shall be bent double to leave a knuckled edge, and should be cut along the rib.

PW Heavy Duty Rib Collars: Custom made 2-7/8" P.W. Heavy Duty Rib Adapter Collars.

Concrete Footing: Footings for OVERHEAD arch shall be 4' deep x 3' in wide. This is to allow the anchors to retain the proper angle going into the footing. This is an important step in insuring that your backstop will be easy to erect, and retain the proper rolled radii. Footings for BASE arch anchor bolts shall be 18" deep x 18" wide. Concrete not included.

Finish: All pipe and hardware is galvanized steel. All fasteners are zinc-plated except anchor bolts.



Date: 7/26/2017

Rev: A

Drawn: BDYE

Sheet: 1 of 17

PRODUCT NAME

ARCH BACKSTOP

MODEL NO.

1212

ITEM NO.	PART NUMBER	DESCRIPTION	QTY.
1	ASA-0500-1212-G	MAIN ANCHOR 1200 ASSEMBLY	2
2	ASA-0501-1200-G	HEAVY DUTY ADJUSTABLE COLLAR	8
3	ASA-0508-1212-G	CENTER REAR TEE FITTING	1
4	ASA-0509-1212-L-G	LEFT TEE FLANGE FITTING	1
5	ASA-0510-1212-R-G	RIGHT TEE FLANGE FITTING	1
6	ASA-0511-1212-R#3-G	2 3/8" RIB #3 ASSEMBLY	2
7	ASA-0512-1212-R#4-G	2 3/8" RIB #4 ASSEMBLY	2
8	ASA-0513-1212-R#5-G	2 3/8" RIB #5 ASSEMBLY	2
9	ASA-0514-1214-R#6-G	2 3/8" RIB #6 ASSEMBLY	2
10	ASA-0515-1212-BR-G	BOTTOM RIGHT BASE ARCH ASSEMBLY	1
11	ASA-0516-1212-BC-G	BOTTOM CENTER BASE ARCH ASSEMBLY	1
12	ASA-0517-1212-BL-G	BOTTOM LEFT BASE ARCH ASSEMBLY	1
13	ASA-0518-1212-FC-G	FRONT CENTER ARCH ASSEMBLY	1
14	RT-0004-1212-FR-G	FRONT RIGHT ARCH	1
15	RT-0006-1212-FL-G	FRONT LEFT ARCH	1
16	RT-0007-1212-R#1-G	RIB #1 DIA.2 3/8"	1
17	RT-0008-1212-R#2-G	RIB #2 DIA.2 3/8"	2
18	RT-019-1200-1000-G	FLATTENED SLEEVE - 1-7/8"	8
19	RT-0016-1212-33.3125-G	HORIZONTAL STIFFENER- 33.3125"	2
20	RT-0017-1212-44.625-G	HORIZONTAL STIFFENER- 44.625"	2
21	RT-0018-1212-46.0625-G	HORIZONTAL STIFFENER- 46.0625"	6
22	RT-0019-1212-45.50-G	DIA.2 3/8" TEE STIFFENER 45.5"	2
23	VCIBB238	2 3/8" BRACE BAND	16
24	VCIBB278	2 7/8" BRACE BAND	2
25	VCITEN278	2 7/8" TENSION BAND	70
26	VCITBAR8	8' TENSION BAR	12
27	VCITBAR12	12' x 3/4" TENSION BAR (142")	2
28	HWLN516	5/16 NYLOCK NUT ZINC	90
29	HWFLWA516	5/16 FLAT WASHER	90
30	HWCB5161	5/16-18 X 1 CARRIAGE BOLT GRADE 2 ZINC	90
31	HWSC3858	3/8 X 5/8 SET SCREW ZINC	26
32	HWHB38114	3/8-16 X 1 1/4 GR5 C/S ZINC HEX BOLT (1000)	8
33	HWHN38	3/8-16 INSERT NYLOK ZINC (2500)	8
34	HWFLWA38	3/8" USS FLAT WASHER	16
35	HWHB123	1/2-13 X 3 GR5 C/S ZINC HEX BOLT (1535)	9
36	HWHB12312	1/2-13 X 3 1/2 GR 5 C/S ZINC HEX CAP SCREW - BOLT	16
37	HWLN12	1/2-13 NYLOK INSERT LOCKNUT ZINC (1500)	25
38	HWSC581	5/8-11 X 1 SET SCREW CUP PT ZINC (BACKSTOP)	16
39	HWDS141	1/4 X 1 ROUND HD U-DRIVE SCREWS ZINC 4000	30
40	VCITIEWIRE	TIE DOWN WIRE 10 1/2"X 12GA WITH HOOK(2000 PER BOX)37 PER	8
41	VCIHOGRINGS	HOG RINGS - HOGR STL 9X 1-9/16 GAL (89 pcs = 1 lb.)	3
42	RMMESHBK2912	2" X 9C (6F) X 12' BLACK MESH KK	100ft
43	HWANCH5812	5/8-11 X 12" ANCHOR BOLT W/NUT PLAIN	3



Date: 7/26/2017

Rev: A

Drawn: BDYE

Sheet: 2 of 17

PRODUCT NAME

ARCH BACKSTOP

MODEL NO.

1212

INSTALLATION INSTRUCTIONS:

- 1) Check materials received with the BOM to make sure that all components are included and to assure that the unit is complete.
- 2) Determine location of backstop so the front arch is perpendicular to a line running from 2nd base through home plate.
3. Dig holes according to Footing Plan below.

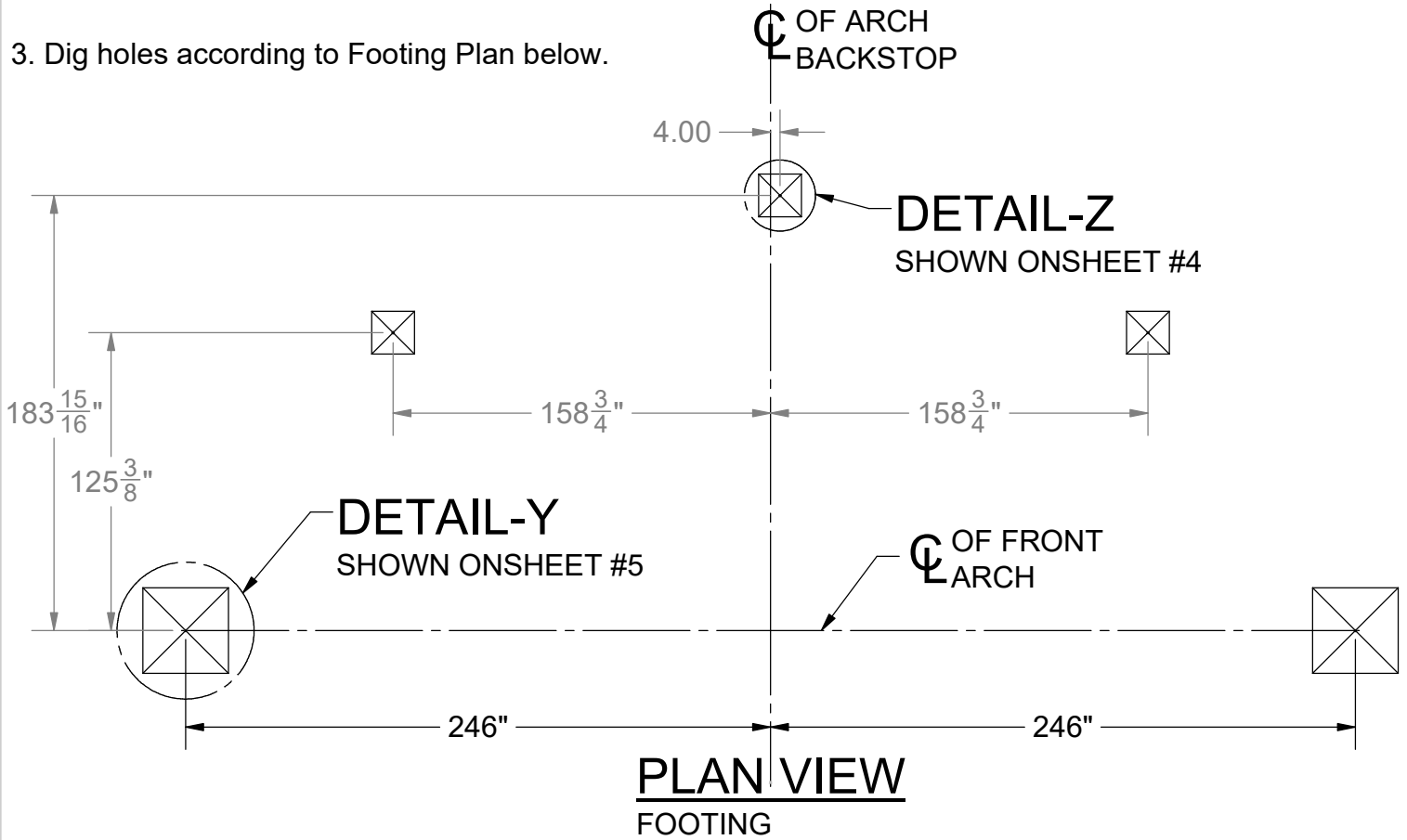

DO NOT POUR CONCRETE UNTIL ENTIRE FRAME IS ASSEMBLED

PW has noted the size of the main anchor footings as a guide line, and asks that you check with your local permit authorizing personnel, or your architect before proceeding, as your area of the country might require larger footings.

Footing must be wide enough to allow anchor to be placed at the approx. angle shown. The angle must be adjusted to form arch and maintain width of backstop. Anchor **MUST NOT** touch sides of footing.

PW has also noted this particular size, so the main anchors may swivel on the base arch to properly align with the overhead arch, the anchor must freely hang in footing and not touch sides of footing. When installing, place the anchors in the base arch, and leave them **FINGER TIGHT ONLY**, at this time. Place the overhead arch onto the main anchors and finger tighten at this time. This allows the overhead arch to settle in the proper angle and sphere to insure trouble free alignment with the ribs.

ONLY after assembling the entire arch, go back and tighten all set screws with proper sized allen wrenches at this time.

	Date: 7/26/2017	PRODUCT NAME ARCH BACKSTOP
	Rev: A	
	Drawn: BDYE	MODEL NO.
	Sheet: 3 of 17	1212

FOOTING DETAIL Z

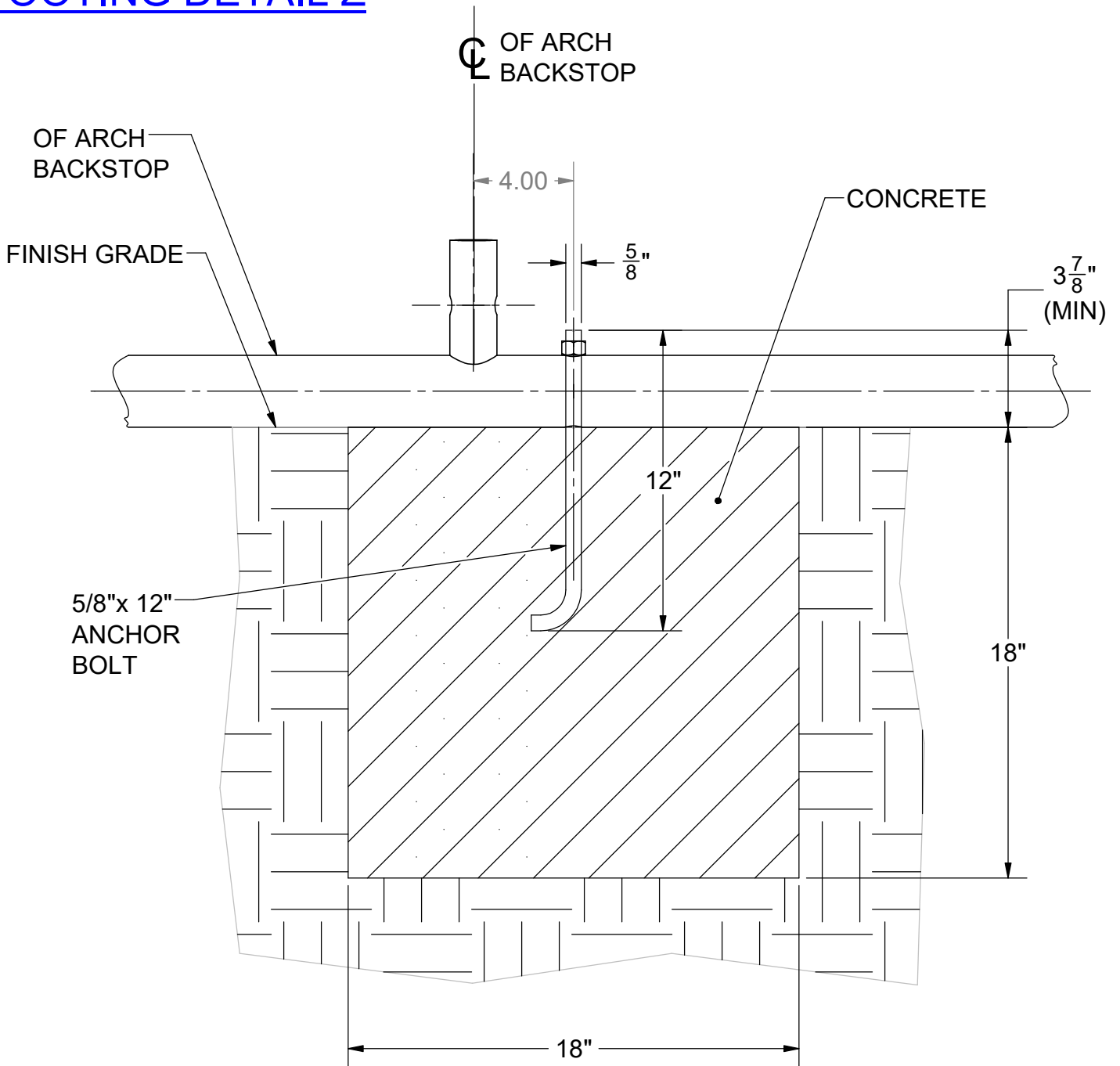

DETAIL-Z
FROM SHEET #3
(TYP 3)



Date: 7/26/2017
Rev: A
Drawn: BDYE
Sheet: 4 of 17

PRODUCT NAME

ARCH BACKSTOP

MODEL NO.

1212

FOOTING DETAIL Y

ARCH BACKSTOP
MAIN ANCHOR

CONCRETE

FINISH GRADE

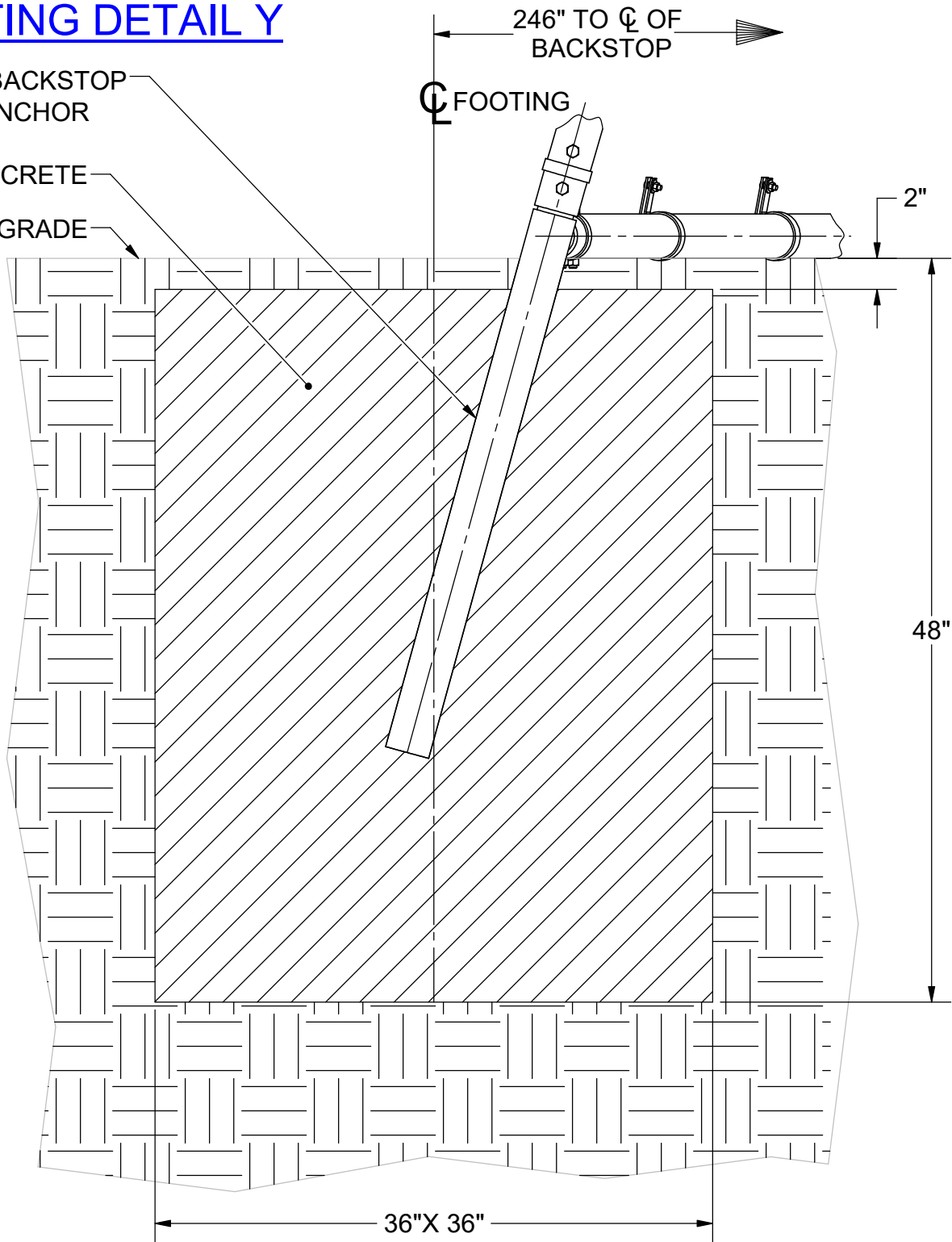

DETAIL-Y

FROM SHEET #5
(TYP 2)



Date: 7/26/2017

Rev: A

Drawn: BDYE

Sheet: 5 of 17

PRODUCT NAME

ARCH BACKSTOP

MODEL NO.

1212

INSTALLATION INSTRUCTIONS:

4) Take Center Bottom Arch Item (11) , Bottom Right Arch Item (10) and Bottom Left Arch Item (12) . Lay on the ground over the footing holes and assemble. Take Center Arch Item (11) and slide sleeve end into Bottom Right Arch Item (10) then use 1/2"x 3 1/2" Bolts Item (36) and 1/2" Nylock Nut Item (37) to bolt the joint together. Take Bottom Left Arch Item (12) and follow the same steps to assemble.

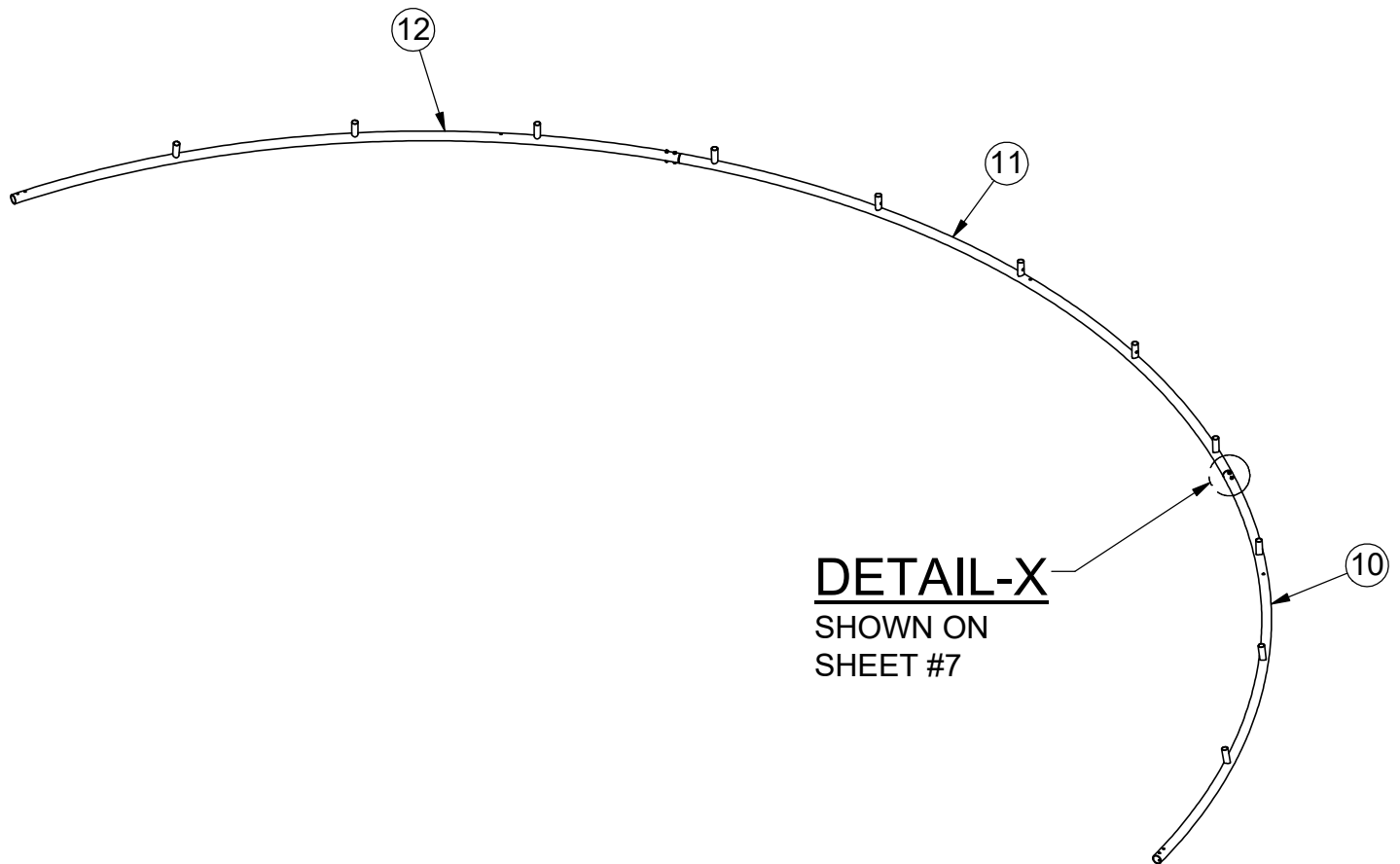

ISOMETRIC



Date: 7/26/2017

Rev: A

Drawn: BDYE

Sheet: 6 of 17

PRODUCT NAME

ARCH BACKSTOP

MODEL NO.

1212

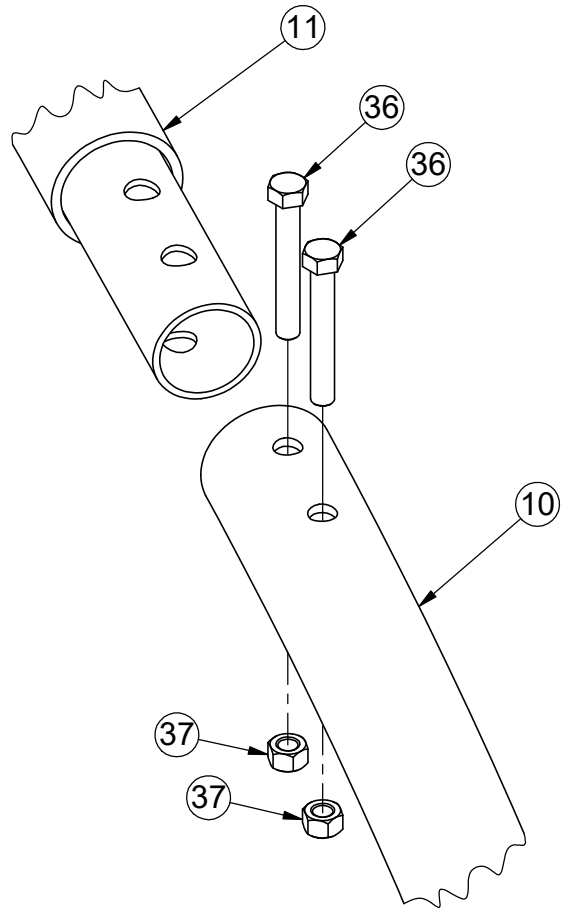

DETAIL-X
FROM SHEET #6



Date: 7/26/2017
Rev: A
Drawn: BDYE
Sheet: 7 of 17

PRODUCT NAME

ARCH BACKSTOP

MODEL NO.

1212

INSTALLATION INSTRUCTIONS:

5) Take Center Front Arch Item (13), Front Right Arch Item (14) and Front Left Arch Item (15). Lay on the ground in front of the Bottom Arch assembly. Take Front Center Arch Item (13) and slide three (3) Heavy Duty Adjustable Collars Item (2) on each end held in place by 3/8"x 5/8" Set Screws Item (31). Only finger tighten Set Screws. (You have to do this operation now because the joint bolts will prevent you from sliding them on later) Take Front Center Arch Item (13) and slide sleeve end into Front Right Arch Item (14) then use 1/2"x 3 1/2" Bolts Item (36) and 1/2" Nylock Nut Item (37) to bolt the joint together. Take Front Left Arch Item (15) and slide over sleeve end of Front Center Arch Item (13) then use 1/2"x 3 1/2" Bolts Item (36) and 1/2" Nylock Nut Item (37) to bolt the joint together.

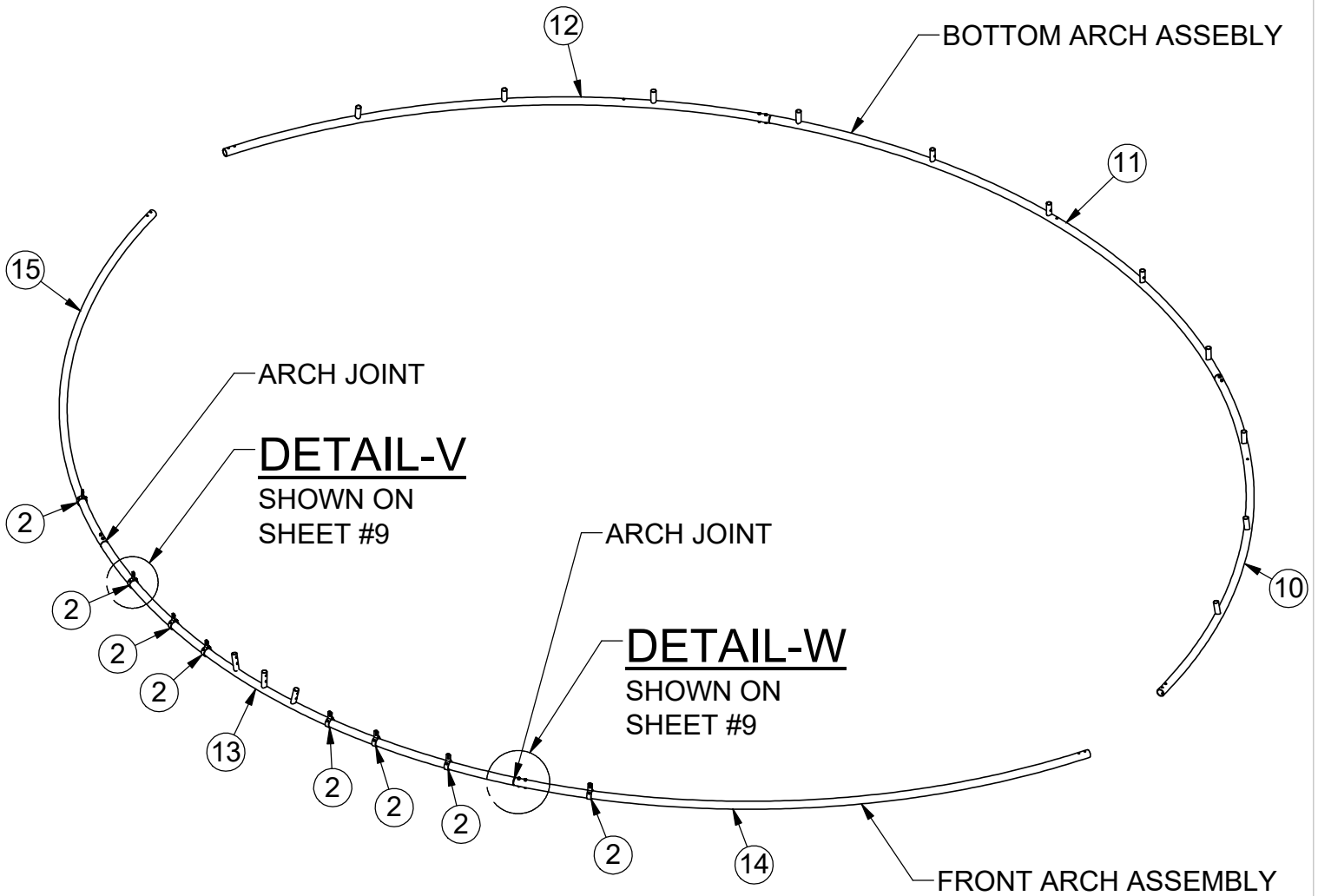

Date: 7/26/2017
 Rev: A
 Drawn: BDYE
 Sheet: 8 of 17

PRODUCT NAME

ARCH BACKSTOP

MODEL NO.

1212

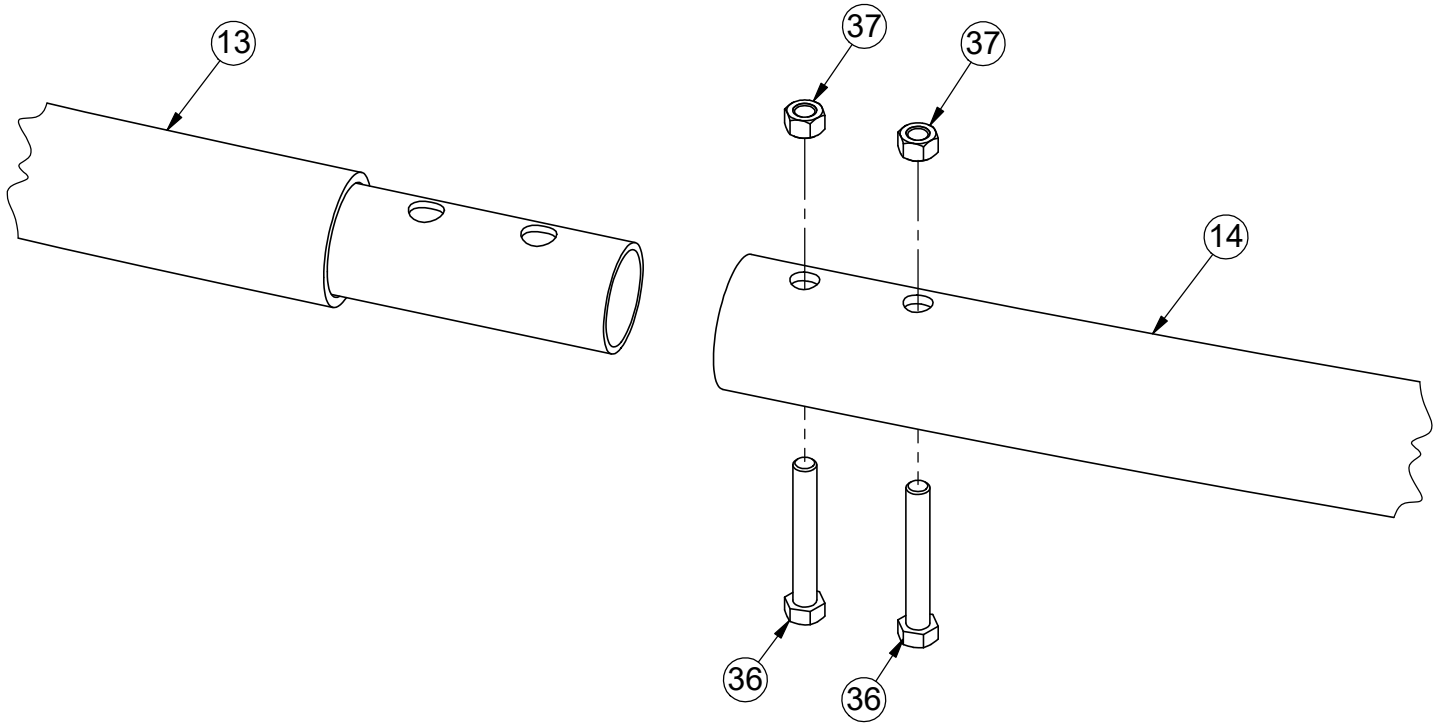

DETAIL-W
FROM SHEET #8

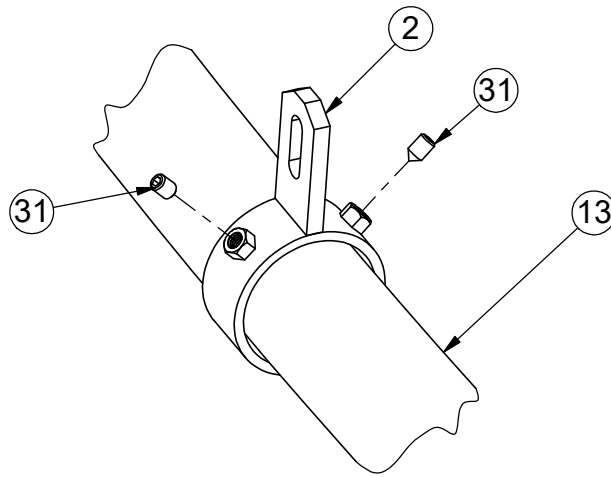

DETAIL-V
FROM SHEET #8



Date: 7/26/2017
 Rev: A
 Drawn: BDYE
 Sheet: 9 of 17

PRODUCT NAME

ARCH BACKSTOP

MODEL NO.

1212

INSTALLATION INSTRUCTIONS:

6) Lift Front Arch Assembly into position and brace in place and slide one (1) Heavy Duty Adjustable Collars Item (2) on each end, held in place by 3/8"x 5/8" Set Screws Item (31) . Only finger tighten Set Screws. (You have to do this operation now because the Main Anchor will prevent you from sliding them on later). Take Main Anchor 1200 Assembly Item (1) and slide Sleeves into Front Arch Assembly and Bottom Arch Assembly for both sides of Backstop and brace in place. Field drill holes into Sleeves of Main Anchor 1200 Assembly Item (1) using a 5/8" drill bit. Use 1/2"x 3 1/2" Bolt Item (36) and 1/2" Nylock Nut Item (37) Shown below and on sheet #11

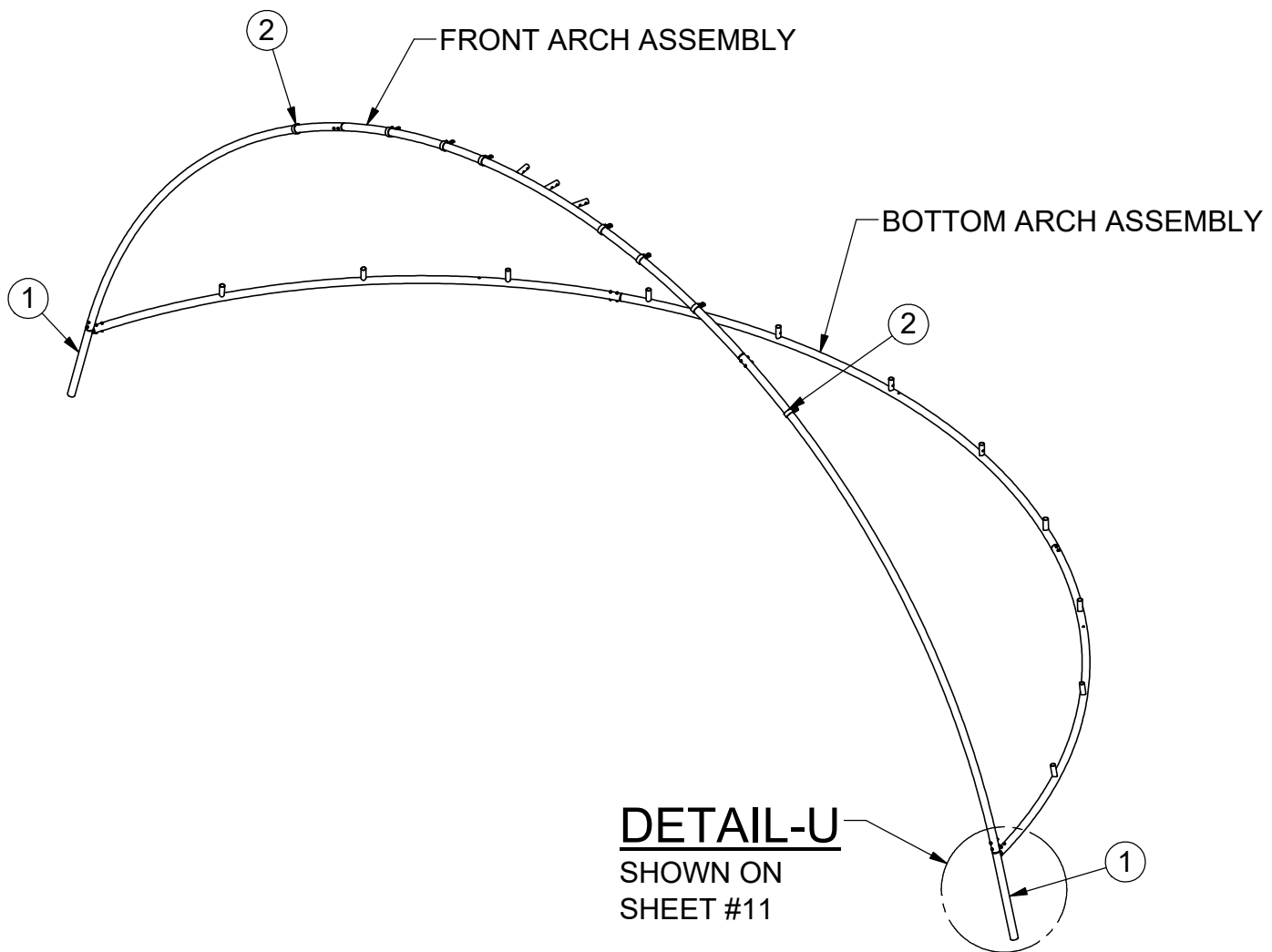

Date: 7/26/2017

Rev: A

Drawn: BDYE

Sheet: 10 of 17

PRODUCT NAME

ARCH BACKSTOP

MODEL NO.

1212

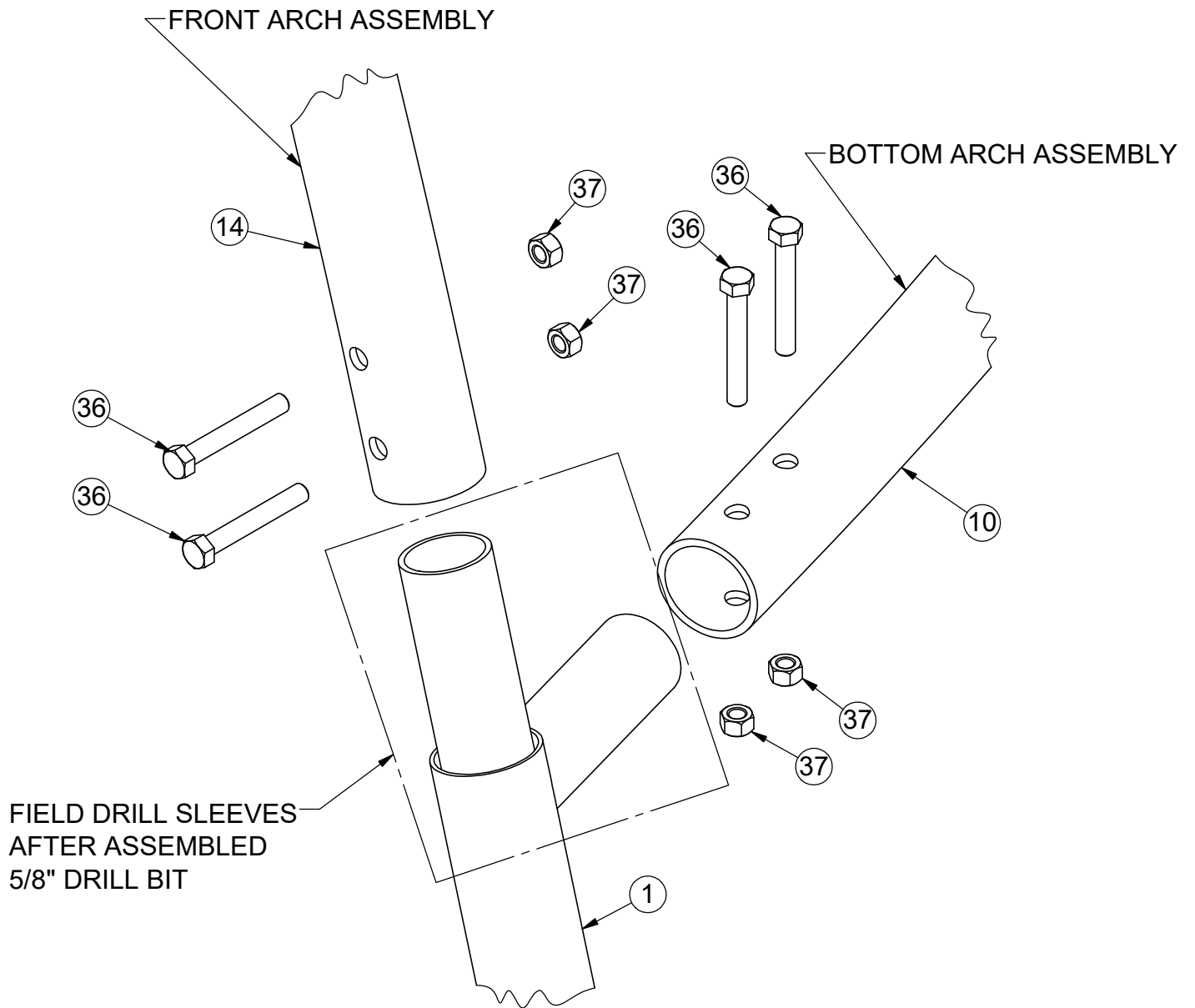

DETAIL-U
FROM SHEET #10



Date: 7/26/2017
 Rev: A
 Drawn: BDYE
 Sheet: 11 of 17

PRODUCT NAME

ARCH BACKSTOP

MODEL NO.

1212

INSTALLATION INSTRUCTIONS:

7) Take #1 Support Rib Item (16) and slide the Center Rear Tee Fitting Item (3) on to the Support Rib as shown below. Next take two (2) #2 Support Ribs Item (17) and slide on Right Tee Flange Fitting Item (5) on one and slide Left Tee Flange Fitting Item (4) on the other as shown below. Next bolt on #1 Support Rib Item (16) by sliding it on the mounting stubs located on the Bottom Arch Assembly and the Front Arch Assembly using 1/2"x 3" Bolts Item (35) and 1/2" Nylock Nuts Item (37). Follow the same directions for bolting on both #2 Support Ribs Item (17) except for placing the Center Horizontal Stiffener 45.50" Item (22) between Ribs as shown.

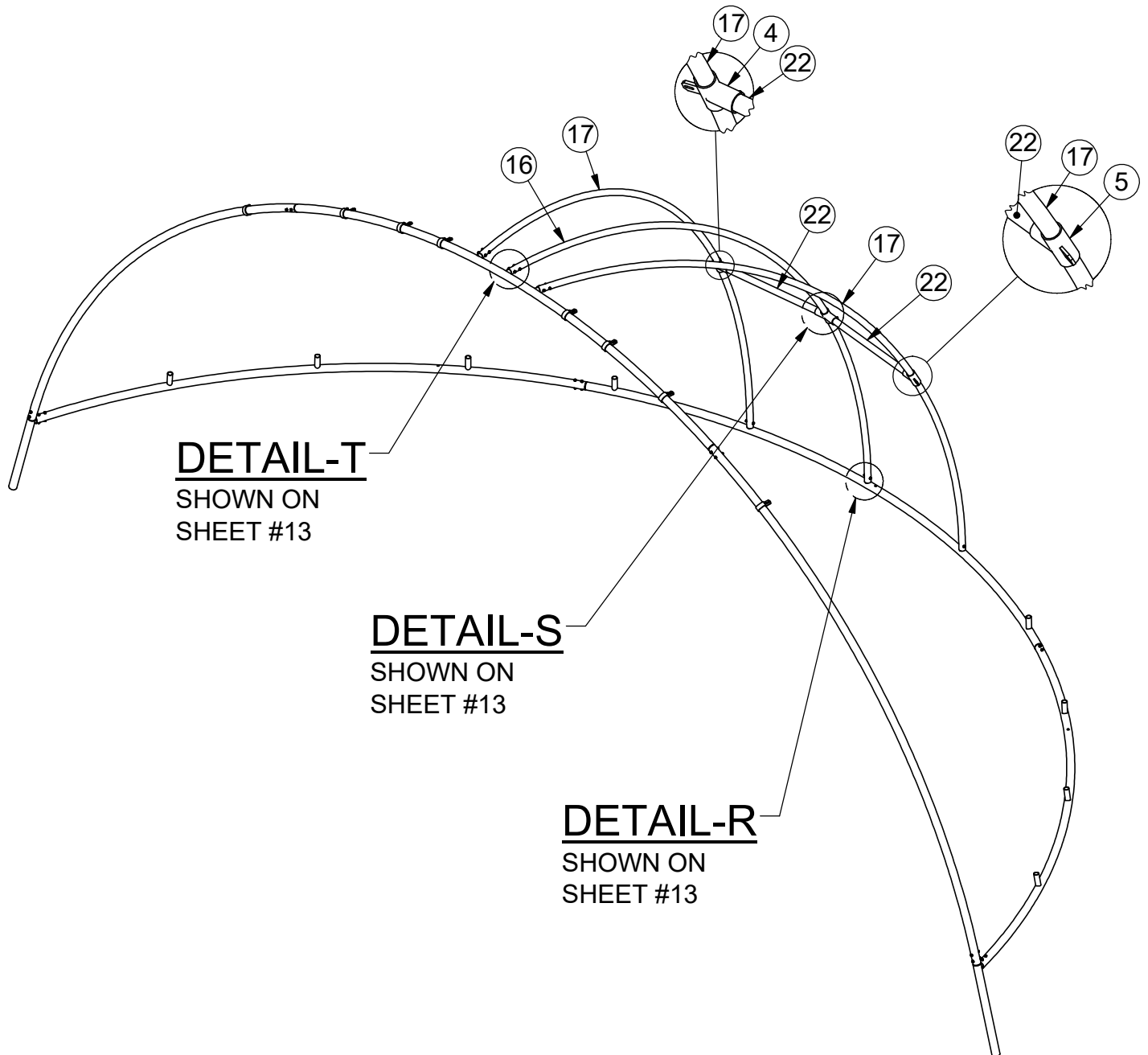

Date: 7/26/2017
 Rev: A
 Drawn: BDYE
 Sheet: 12 of 17

PRODUCT NAME

ARCH BACKSTOP

MODEL NO.

1212

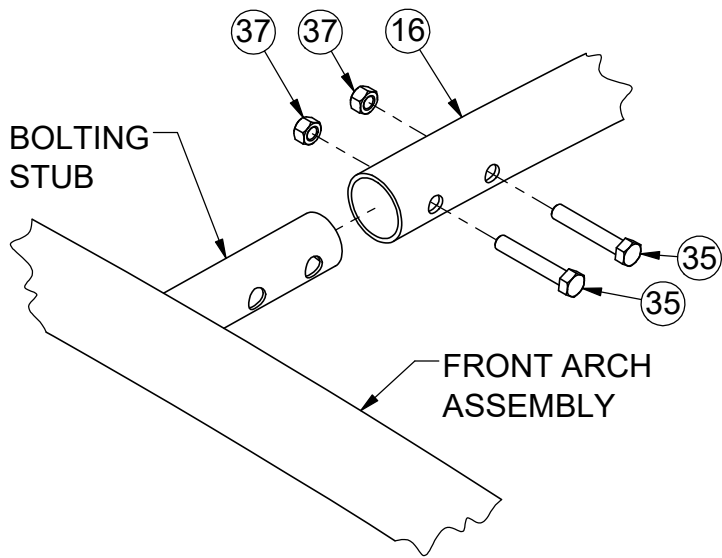

DETAIL-T
FROM SHEET #12

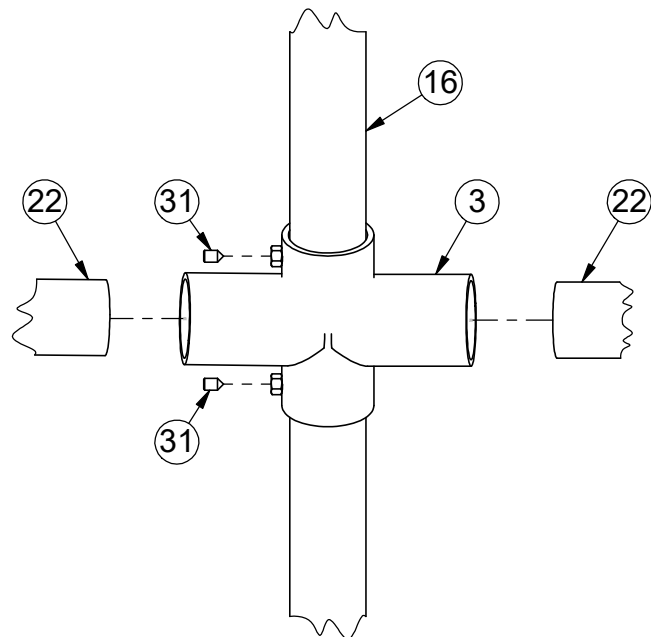

DETAIL-S
FROM SHEET #12

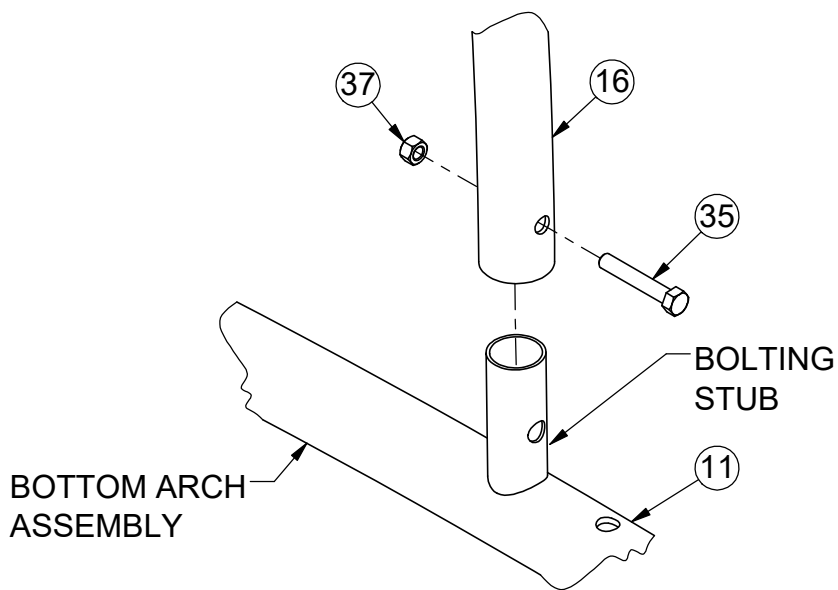

DETAIL-R
FROM SHEET #12



Date: 7/26/2017
 Rev: A
 Drawn: BDYE
 Sheet: 13 of 17

PRODUCT NAME
ARCH BACKSTOP
 MODEL NO.
1212

INSTALLATION INSTRUCTIONS:

8) Take #3 thru #6 Support Rib Items (6) (7) (8) (9) and bolt on by sliding them on the mounting stubs located on the Bottom Arch Assembly by using 5/8"x 1" Set Screw Item (38) . Attach the top of the Ribs to the Front Arch Assembly with the Flattened Sleeve Item (18) with 5/8"x 1" Set Screw Item (38) , Heavy Duty Adjustable Collar Item (2) , 3/8"x 1 1/4" Hex Bolts Item (32) , 3/8" Washer Item (34) and 3/8" Nylock Nut Item (33) . Follow the directions to install the remaining Ribs listed above. The views below, sheet #15 and #16 will show you the steps.

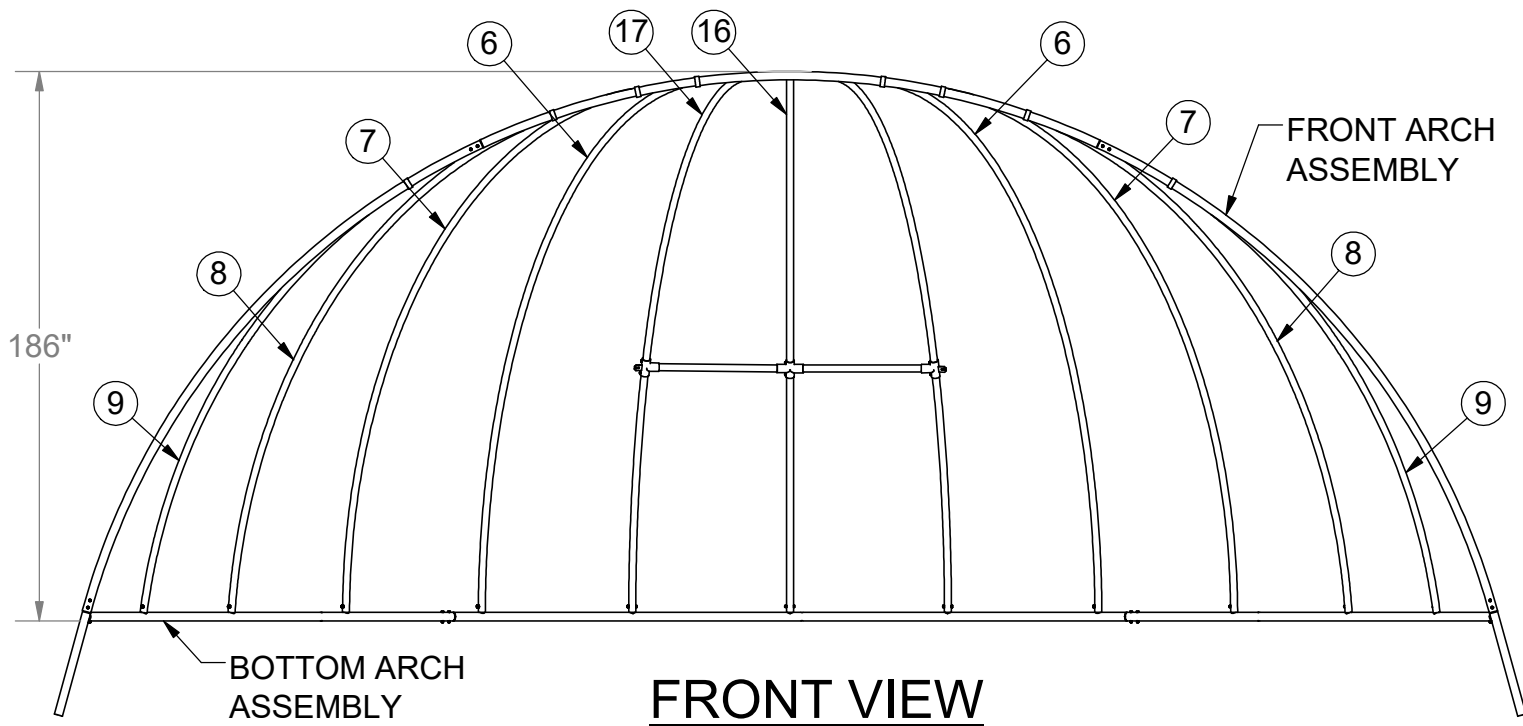
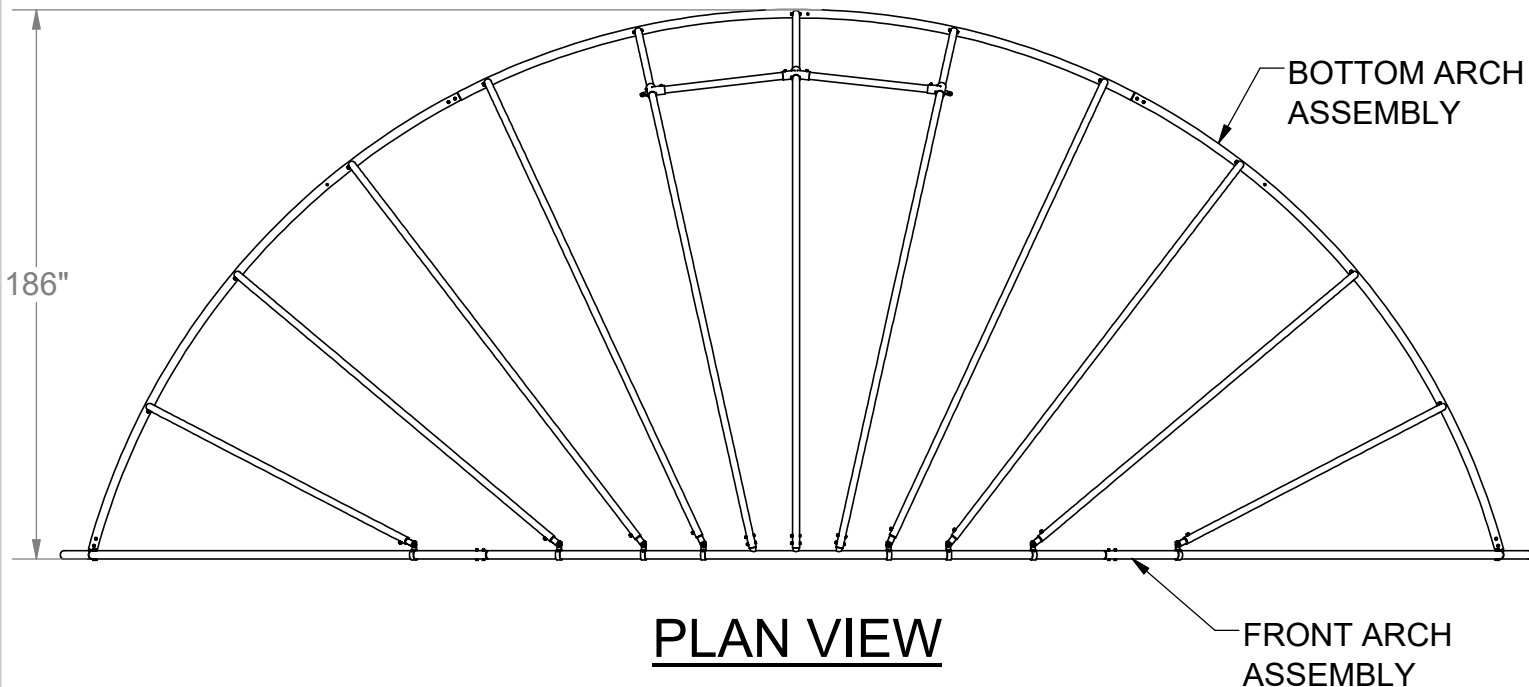

Date: 7/26/2017
 Rev: A
 Drawn: BDYE
 Sheet: 14 of 17

PRODUCT NAME

ARCH BACKSTOP

MODEL NO.

1212

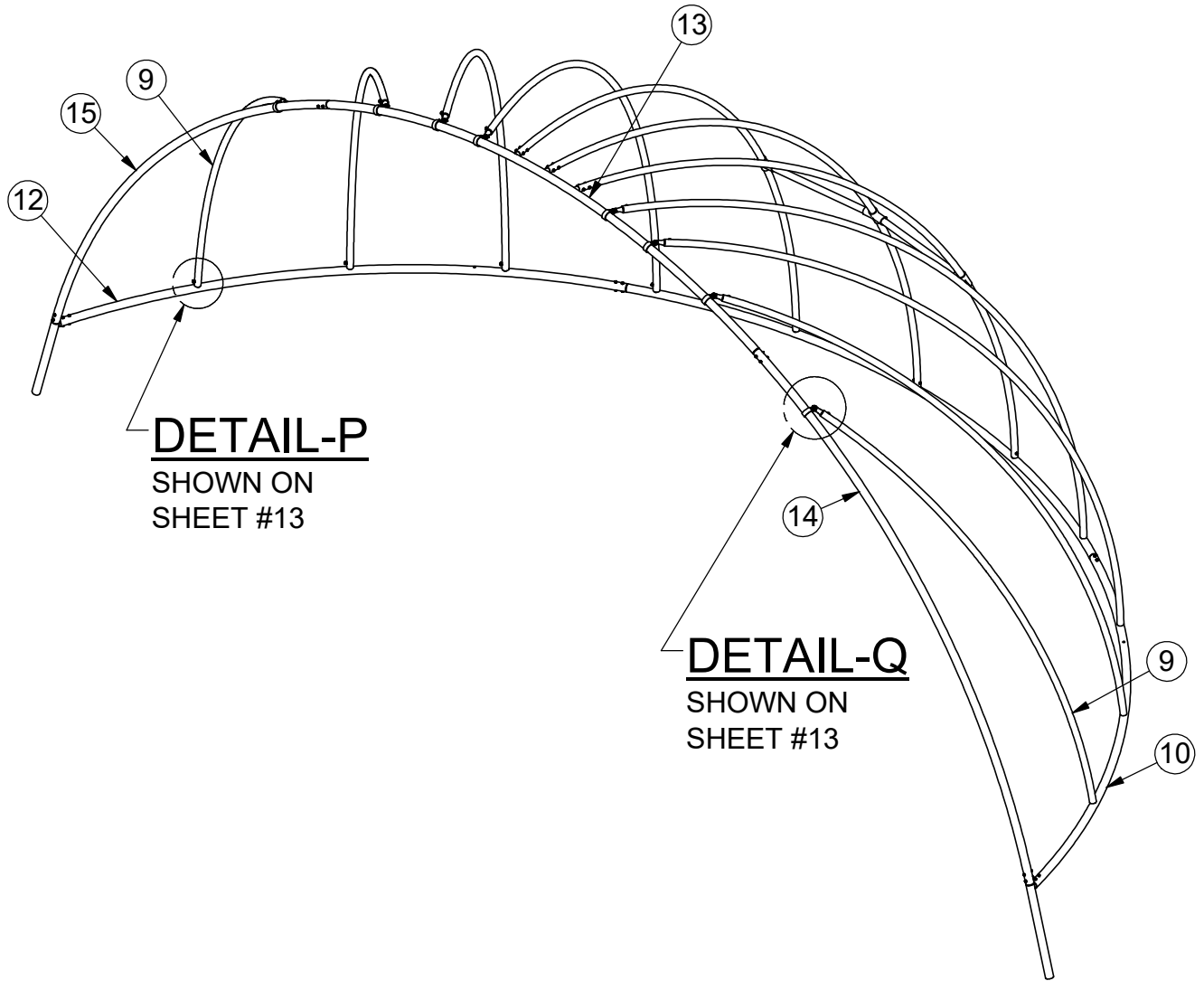

ISOMETRIC



Date: 7/26/2017
 Rev: A
 Drawn: BDYE
 Sheet: 15 of 17

PRODUCT NAME

ARCH BACKSTOP

MODEL NO.

1212

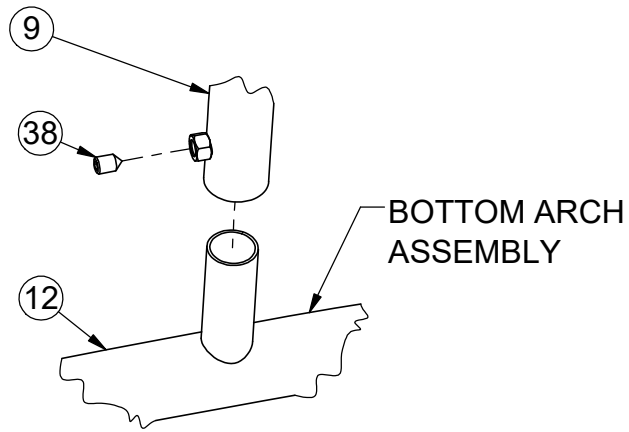

DETAIL-P
FROM SHEET #15

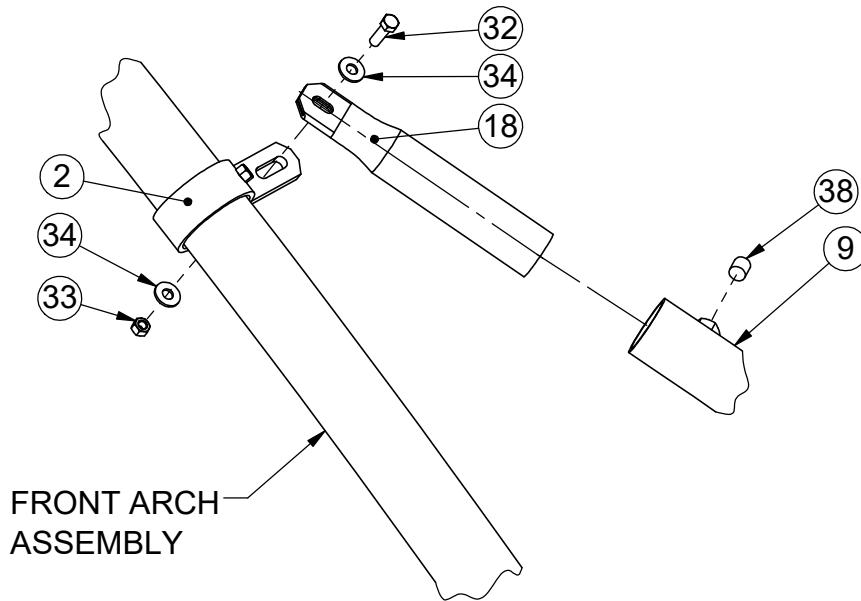

DETAIL-Q
SHEET #15



Date: 7/26/2017
 Rev: A
 Drawn: BDYE
 Sheet: 16 of 17

PRODUCT NAME

ARCH BACKSTOP

MODEL NO.

1212

INSTALLATION INSTRUCTIONS:

9) To install Horizontal Stiffeners (19) thru (22) with Brace Bands (23) and (24) by following the views below. Make sure to alternate Horizontal Stiffeners as shown to make sure the bottom of every other one is 84" to Finish Grade.

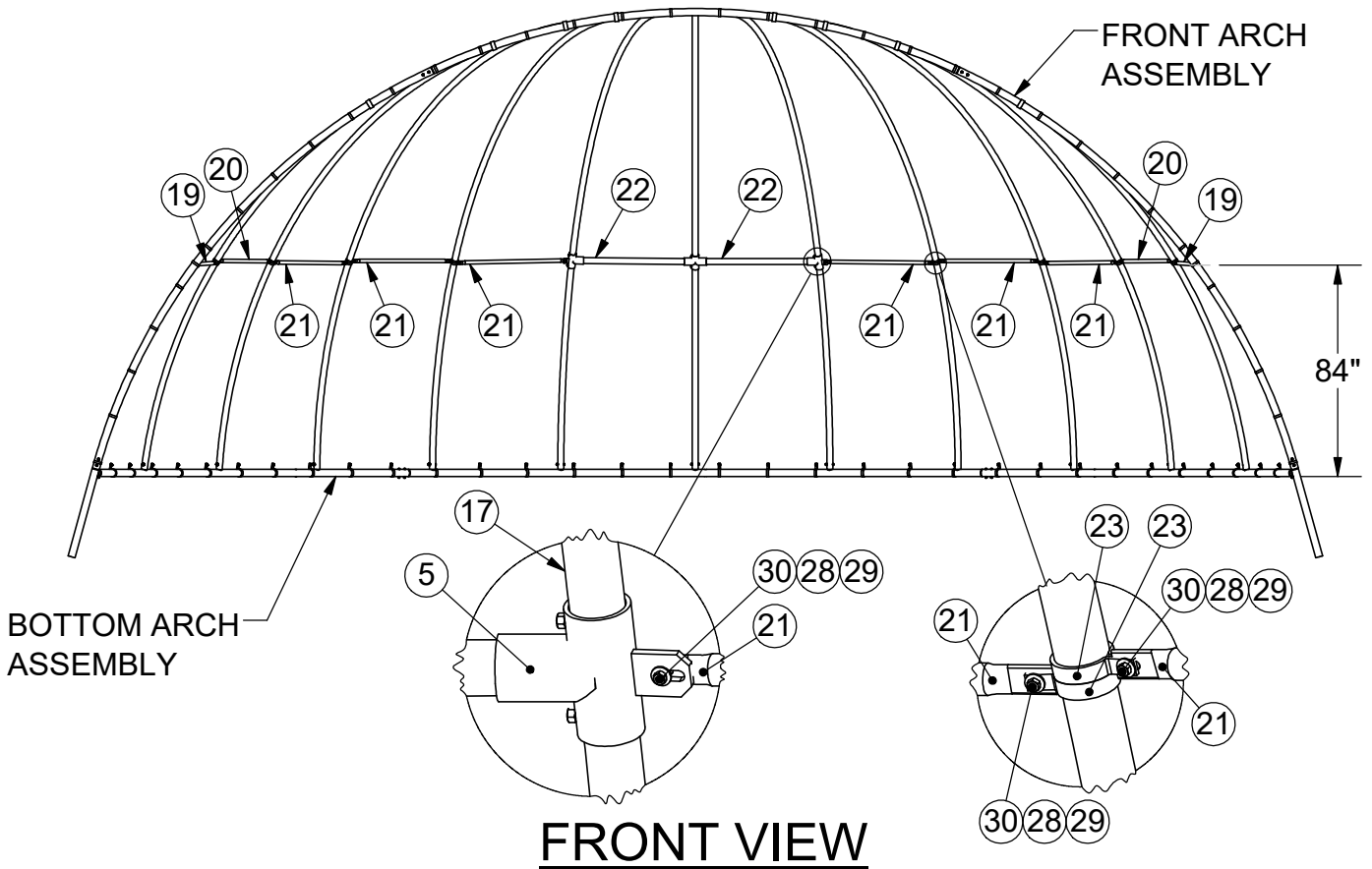
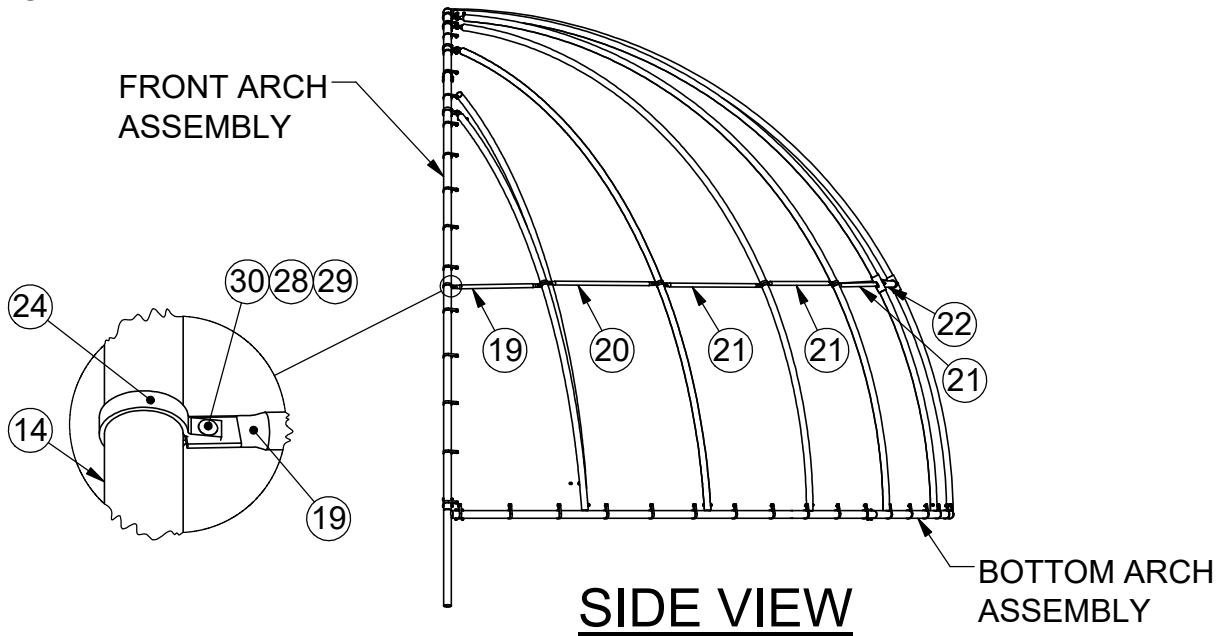

Date: 7/26/2017
 Rev: A
 Drawn: BDYE
 Sheet: 17 of 17

PRODUCT NAME

ARCH BACKSTOP

MODEL NO.

1212