

40' PERPENDICULAR ARCH BACKSTOP

- MODEL #1212-05 - ARCH BACKSTOP 15'6"H x 15'6"D x 40'W W/5 FT. EXTENSION (3,050 LBS)
- MODEL #1212-10 - ARCH BACKSTOP 15'6"H x 15'6"D x 40'W W/10 FT. EXTENSION (4,150 LBS)

OVERHEAD and BASE Arches: 2-7/8" O.D. galvanized steel.

Vertical Ribs: 2-3/8" O.D. galvanized steel. Ribs shall be formed to a smooth continuous radius throughout the entire length of each rib.

Flattened Sleeves: 1-7/8" O.D. galvanized steel, factory flattened and punched.

Horizontal Stiffeners: 1-3/8" O.D. galvanized steel, secured between vertical ribs with 2-way split clamps (galvanized), zinc plated 5/16" x 1-1/4" carriage bolts split washers and hex nuts. Where stiffeners connect to outside ribs, 3/4" wide galvanized steel brace bands shall be used along with 5/16" x 1" carriage bolts split washers and hex nuts. Any exposed threads to be destroyed by Installer.

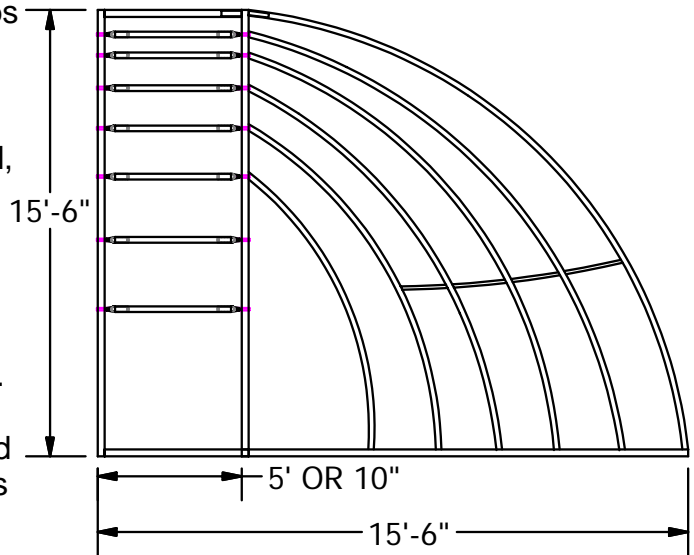

 <p>Patterson-Williams QUALITY ATHLETIC AND PARK EQUIPMENT SINCE 1919</p>	Date: 5-22-08	SPECIFICATION/INSTALLATION INSTRUCTIONS
	Rev: A032812	
	Drawn: AMC	MODEL NO.
	Sheet: 1 of 9	1212-05 & 1212-10

Main Footing Anchors: 2-7/8" O.D. galvanized steel, welded sleeves that fit into BASE and OVERHEAD arch ends (2-3/8" O.D. galvanized steel). Footing anchors shall extend 3 feet into footings and shall be welded at the bottom with one piece of 6" long angle (2" x 2" x 3/16") steel, to form an anchor in the concrete footing.

Anchor Bolts: 5/8" x 12" foundation bolts, extending throughout BASE arch and shall be evenly spaced between vertical ribs. Any exposed threads to be destroyed by Installer.

Tension Bars: 3/4" galvanized and shall be secured with galvanized tension bands spaced 18 inches on center and bolted with 5/16" x 1" zinc-plated carriage bolts lock washers and hex nuts. Threads to be destroyed by Installer 10 feet up on overhead arch. Tension bars shall be installed along inside overhead arch.

Chain Link Fabric: Fabric shall be 9-gauge on all models except top (second) course shall be 11-gauge. It shall be installed horizontally in single lengths to outside of backstop using 12-gauge galvanized wire ties every 18 inches along vertical ribs. Edges shall be over-lapped a minimum of 1" to 2" and tied together with 9-gauge, #3 galvanized hog rings every 6 inches along seams. Fabric shall be pulled tight around curvature of backstop and shall be cut and trimmed in a neat and professional manner. Where wire is cut, exposed barbs shall be bent double to leave a knuckled edge, and should be cut along the rib.

PW Heavy Duty Rib Collars: Custom made 2-7/8" P.W. Heavy Duty Rib Adapter Collars.

Concrete Footing: Footings for OVERHEAD arch shall be 4' deep x 3' in wide. This is to allow the anchors to retain the proper angle going into the footing. this is an important step in insuring that your backstop will be easy to erect, and retain the proper rolled radii. Footings for BASE arch anchor bolts shall be 18" deep x 18" in. Concrete not included. See footing details on page 9.

Finish: All pipe and hardware is galvanized steel. All fasteners are zinc-plated except anchor bolts.

5' & 10' Extension & Overhead Extension Specifications:

Overhead Arch Extension: 2-7/8" O.D. galvanized steel.

Rib Extensions: 2-3/8" O.D. pipe. Rib extensions are included only on models equipped with optional overhead extension arch. There shall be one rib extension per vertical rib plus two ribs per side, equally spaced between the top of the end ribs and the base arch. Rib extensions connect the overhead extension arch to the overhead arch.

Overhead Extension Arch & Base Extension: 2-7/8" O.D. pipe, same as overhead and base arches described above. Extensions of 5-feet and 10-feet are available on perpendicular models only.

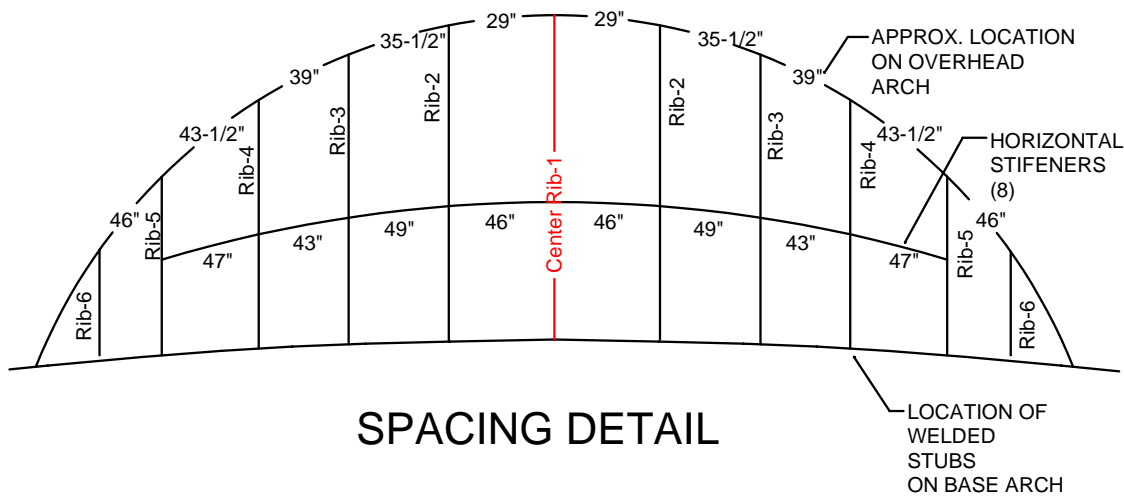

SPACING DETAIL

 <p>Patterson-Williams ATHLETIC MFG. CO. QUALITY ATHLETIC AND PARK EQUIPMENT SINCE 1919</p>	Date: 5-22-08	SPECIFICATION/INSTALLATION INSTRUCTIONS 40' PERPENDICULAR ARCH BACKSTOP
	Rev: A032812	
	Drawn: AMC	MODEL NO.
	Sheet: 2 of 9	1212-05 & 1212-10

GENERAL NOTES:

- I. Check materials received with the parts list (Page 10) to make sure that all components are included and to assure that the unit is complete.
- II. The site must be level not more than + 1" variation from mean elevation over the entire length and depth of the base arch.
- III. A construction-type forklift with a 20-foot boom capacity and scaffold will be necessary to assemble frames and attach wire mesh.
- IV. For maximum ball-capture, the overhead arch should be directly over home plate.
- V. The base and overhead arches are 2-7/8" O.D. and consist of three curved sections. The center sections of both the overhead and base arches have internal sleeves (2-3/8" O.D.) welded on each end and another external sleeve (1-7/8" O.D.) welded in the middle. They are marked as follows:

Left end - BASE Arch	B-1	Center - BASE Arch	B-2	Right end - BASE Arch	B-3
Left end - OVERHEAD Arch	O-1	Center - OVERHEAD Arch	O-2	Right end - OVERHEAD Arch	O-3
Left end - OVERHEAD EXT.	OE-1	Center - OVERHEAD EXT.	OE-2	Right end - OVERHEAD EXT.	OE-3

Extremely Important: Position center arch O2 so that the welded stubs are facing in the proper direction (the angled stub to rib #1, and the 90° stub towards extension arch OE2. Overhead arch is marked)

Before assembling the overhead arch & extension arch:

- 1. On center arch (O2) slide six (6) adjustable adapters on each side of welded sleeve, & three (3) adapters on each side of welded sleeve on extension arch (OE2). (See Detail page 7)
- 2. On left arch and right arch, slide six (6) adjustable adapters on O1 & O3, and four (4) on OE1 & OE3.
- 3. Secure sections with 5/8" x 4" Hex Bolts, Washer, and Nylocks.

DO NOT POUR CONCRETE UNTIL ENTIRE FRAME IS ASSEMBLED

PW has noted the size of the main anchor footings as a guide line, and asks that you check with your local permit authorizing personnel, or your architect before proceeding, as your area of the country might require larger footings.

PW has also noted this particular size, so the main anchors may swivel on the base arch to properly align with the overhead arch, the anchor must freely hang in footing and not touch sides of footing. When installing, place the anchors in the base arch, and leave them FINGER TIGHT ONLY, at this time. Place the overhead arch onto the main anchors and finger tighten at this time. This allows the overhead arch to settle in the proper angle and sphere to insure trouble free alignment with the ribs.

ONLY after assembling the entire arch, go back and tighten all set screws with proper sized allen wrenches.

FRAME ASSEMBLY

- 1. Assemble the Base Arch:
 - 1.1 Locate the three sections of the base arch. (B-1, B-2 & B-3) (Standing inside the base arch B-1 and B-3 are on your left and right respectively).
 - 1.2 Begin by connecting the three sections (B-1, B-2 & B-3) of the base arch together using the set screws provided. Make sure the end sleeves on B-2 are fully seated. Set in proper field location. Measure 40' on center end to end and adjust as necessary to conform to the 40' dimension. Mark the location of the main footings at each end of the base arch. Mark the 10 anchor bolt locations at each pre-drilled hole on B-1, B-2 and B-3.
 - 1.3 Move base arch aside and dig footings. Main anchor footing dimensions are 36" diameter x 48" deep. Note: MAIN ANCHOR FOOTINGS SHOULD BE DUG TO ACCOMODATE THE ANGLE OF THE ANCHORS. Center the anchors in footing hole. (See Detail B page 9)
 - 1.4 Relocate base arch to match footing locations. Measure center to center on base arch ends again and hold 40' dimension. Stake rear of base arch to prevent sliding when installing overhead arch. Note: Footing sizes are based on average soil conditions. Loose and/or sandy soil is not average and footing sizes must be increased accordingly to meet local soil conditions.



Date:	5-22-08
Rev:	A032812
Drawn:	AMC
Sheet:	3 of 9

SPECIFICATION/INSTALLATION INSTRUCTIONS
40' PERPENDICULAR ARCH BACKSTOP
MODEL NO.
1212-05 & 1212-10

2. Assemble the Overhead Arch (Reference important note on page 3):
 - 2.1 Locate three sections of overhead arch (O-1, O-2 and O-3) and lay them on the ground in front of and directly opposite the base arch. (Standing inside the overhead arch) O-1 and O-3 will be on your left and right respectively). Make sure end sleeves on O-2 are fully seated. Join the sections together using 5/8" x 4" Hex Bolts provided. Tighten before lifting overhead arch in the air.
 - 2.2 Raise assembled overhead arch into position using a forklift. Insert main footing anchors into both ends of base arch. Lower the overhead arch onto main footing anchors until fully seated. Leave forklift in position to support the overhead arch until vertical ribs are installed.
 - 2.3 At connecting locations on the main footing anchors use set screws to hold in place. until entire frame is assembled.

CRITICAL NOTE: AFTER OVERHEAD ARCH, BASE ARCH, AND RIB#1 IS UP, STOP TO VERIFY OVERALL MEASUREMENTS (WIDTH, HEIGHT, AND DEPTH INCLUDING VISUAL INSPECTION OF ALIGNMENT) BEFORE PROCEEDING. USE A RACHET STRAP TIED AT EACH END OF THE BASE ARCH TO KEEP WIDTH DIMENSION IN PLACE UNTIL FRAME IS COMPLETELY ASSEMBLED.

3. Install Vertical Ribs:

3.1.1 All vertical ribs are marked with numbers and should be installed in this order. Rib #1 is the center fixed rib. Insert bottom of center rib onto welded stub on the base arch. Hold back overhead arch and insert the top of rib #1 onto stub of overhead arch. Make sure rib and sleeve are seated on overhead & base arch. Tighten set screws to hold in place.

Note: After Overhead Arch, Base Arch, and Rib #1 is up, STOP! and verify measurements (Width, Height, and Depth) and also check side view to verify arch is perpendicular to field before proceeding.

3.1.2 Horizontal stiffeners are used between the ribs. There are different lengths of horizontal stiffeners. See Clamp Spacing Detail H on page 7 for correct location of each stiffener. Assemble one split half clamp on rib #1 using 5/16" x 1-1/4" carriage bolts, split washers and hexnuts and attach stiffener (46") to each side of clamp. Slide stiffeners and clamps up the rib to approximately 6' above finish grade. Only tighten bolts enough to hold in place.

3.1.3 To install remaining ribs, locate the rib adapter collars that were slid onto the overhead arches done before step 1. Locate the flattened end sleeves. (See Detail D & E page 7) Insert flattened sleeve into top of rib #2 and assemble to rib collar.

3.1.4 In an alternating sequence, install the remaining ribs, 2, 3, 4, & 5, installing one rib to each side of previous rib. (See Detail page 9) Do not tighten bolts fully tight until all stiffeners and clamps are in place.

3.1.5 Attach ribs #6 to top and bottom arches and use stiffeners (see detail page 9) to hold them in place. Use 2-3/8" brace bands on end of stiffener. Adjust ribs and stiffeners as needed for horizontal and vertical continuous curved appearance.

3.1.6 Make sure all sleeved joints are seated and proceed to tighten all bolts and set screws.

3.1.7 Install anchor bolts and nuts in the holes on base arch. Thread nuts on anchor bolts until two threads are protruding out of nut. Make sure the anchors are centered in footing holes. (See Detail D page 9)

4.0 Assemble the OVERHEAD arch extension (See "Extremely Important" note page 3)

4.1 Extend the BASE arch on ends with 2-7/8" OD pipe (56-1/2" for 5' Ext. or 116-1/2" for 10' Ext.) Sleeve the pipe onto the main footing anchors and use set screws to hold in place. (See Footing Details on page 9)

4.2 Insert footing anchors into other end.

4.3 Locate the three sections (OE-1, OE-2, & OE-3) and sleeve the sections together until fully seated as in Step 2.2 using the 5/8" x 4" thru-bolts provided. Note: The center stub on OE-2 will now face the 1st OVERHEAD ARCH. Remember to slide P.W. Heavy Duty Clamps on first.

4.4 Raise OVERHEAD arch extension and sleeve onto footing anchor as in Step 3. Note: Stake anchors to hold in place until extension ribs are installed.

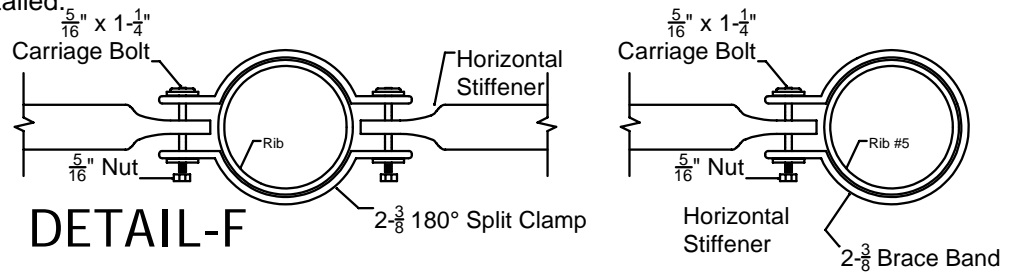

Date:	5-22-08
Rev:	A032712
Drawn:	AMC
Sheet:	4 of 9

SPECIFICATION/INSTALLATION INSTRUCTIONS
40' PERPENDICULAR ARCH BACKSTOP
MODEL NO.
1212-05 & 1212-10

Note: Center rib extension and base extensions are longer than remaining rib extensions.

- 4.5 Assemble rib extensions (See Detail on page 9)
- 4.6 Sleeve the 2-3/8" OD pipe (56-1/2" for 5' Ext. or 116-1/2" for 10' Ext.) onto the stub on O-2 of the 1st OVERHEAD arch and the center stub on OE-2 of the OVERHEAD arch extension.
- 4.7 At each rib location use a 2-3/8" OD pipe (46" for 5' Ext. or 106" for 10' Ext.), 2-7/8" P.W. H.D clamp and flattened sleeve to extend the ribs out to the OVERHEAD arch extension. Use set screw to hold in place.
- 4.8 Evenly space the last two pipe extensions on either side of the arch between the last rib extension and the ground.
- 4.9 Check for overall frame alignment and adjust frame before pouring concrete. Pour concrete in the large main footing holes to within 2" of finished grade. Pour anchor bolt footings up to finished grade. Allow concrete to set for 3 days before completion of install. After footings have set cover main footings with dirt or turf. Note: Footing sizes are based on average soil conditions. Loose and/or sandy soil is not average and footing sizes must be increased accordingly to meet local soil conditions.

NOTE: BEFORE CONTINUING, PERFORM A VISUAL INSPECTION. CONFIRM THAT THE OVERHEAD ARCH IS STRAIGHT & PERPENDICULAR TO THE BASE ARCH, AND THAT THE RIBS FORM A SMOOTH CURVATURE ALONG THE BACK SIDE OF THE ARCH.

5. WIRE MESH INSTALLATION:

Mesh goes on in 2 courses

- 5.1 FIRST COURSE: - 1st or Bottom Course: 2"-9ga x 12' width, 60' long.
- 5.2 Cut 10' off one roll and splice the two lengths of 12' -9ga mesh into one 60' length.
- 5.3 Stand the wire up on edge and position on the outside of the frame so the bottom edge is flush with the bottom of the base arch and is centered. Secure the mesh to the center rib only with tie-wire on 18" centers. Pull the mesh tight to each end. Trim the excess on the bias about 2" short of the overhead arch at both ends to allow room for tension bars and bands.
- 5.4 Install one 12' tension bar in the mesh at each end (parallel to overhead arch) so the tops of the bars are flush with the top of the mesh. Where the bars do not fit through the mesh properly the cut ends of the wire must be twisted around the bars to prevent unraveling of the mesh. Make sure there are no exposed sharp wires. (See Mesh Detail page 6.)
- 5.5 Pull mesh tight as possible as it will save having extra work later. Install tension bands on 18" centers on the overhead arch up to the top of the mesh. Secure bands with 5/16" x 1" carriage heads facing outside. Tighten hardware securely.
- 5.6 If the top few feet of the mesh are still loose or sag between ribs, proceed with this step. Starting at the center rib at the top of the mesh cut the mesh along the rib downward to about 12" above where the mesh is tight. NOTE: Never cut the mesh more than 12" below the stringers (1-1/16" O.D. pipe between the ribs). Pull the mesh tight starting at the bottom of the cut working upward using hog rings to secure approximately every other diamond. Cut away the excess (the usual amount of excess at the top is 4" to 6") allowing enough wire to twist the cut ends together. Use more hog rings and/or tie wire as necessary to completely secure the seam. (See Mesh Detail page 6.)
- 5.7 If the top of the mesh is still loose or sags, repeat step #5.6 for each rib until it is tight. NOTE: This does not necessarily need to be done at every rib only until tight. Work from center rib outward alternating right and left. At some of the outer ribs cutting may not be necessary but it may be necessary to gather one or two strands of mesh and secure with hog rings.
- 5.8 Secure the mesh to all of the ribs with tie wire on 18" centers.

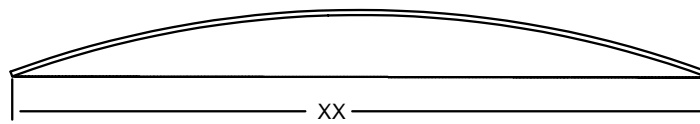

CHORD LENGTH

Note: Chord length measured in a straight line from one end of pipe to other end.

 <p>Patterson-Williams ATHLETIC MFG. CO. QUALITY ATHLETIC AND PARK EQUIPMENT SINCE 1919</p>	Date: 5-22-08	SPECIFICATION/INSTALLATION INSTRUCTIONS
	Rev: A032712	
	Drawn: AMC	MODEL NO.
	Sheet: 5 of 9	MODEL NO. 1212-00

Install the bottom 8' tension bars in the second diamond up from the bottom of the mesh. Feed the bars through the mesh starting at one end working to the opposite end. Overlap the ends of the tension bars a few inches at the ends. The last tension bar must be cut to size so it fits flush with the inside edge of the overhead arch. NOTE: The bars must be installed after the mesh is tight (if not, the mesh will not conform to the shape of the backstop).

5.10 To install tension bands, it may be necessary to loosen nuts on anchor bolts and raise the base arch slightly so they will fit underneath. Install bands on 18" centers all along the base arch. Secure with 5/16" x 1" carriage bolts with heads facing outside of the tension bars along the base arch. Use hog rings to secure overlap of tension bars.

5.11 Tighten anchor bolt nuts securely so the base arch is in contact with the anchor bolt footings. Peen any excess threads to prevent removal.

6. SECOND TOP COURSE: - 2nd or Top Course: 2"-9ga x 12' width, 40' long

6.1 The remaining wire, 2" -9ga x 12' wide x 40' long, is the second course. Center the mesh on the frame so the top edge is flush with and parallel to overhead arch. The excess mesh at the bottom of the second course will overlap the top of the first course. (Do NOT trim at this time)

6.2 Install an 8' tension bar in the mesh at the center where the center rib (rib #1) sleeves to the overhead arch. Working from the center out, install tension bands on 18" centers while stretching mesh tight in an outward direction.

6.3 Stretch the mesh downward and secure to the center rib with tie wire on 18" centers.

6.4 Add remaining bars and bands as before alternating from left to right center. While pulling the mesh tight in an outward direction along the overhead arch. Allow 2" of overlap at the ends of the tension bars. Cut the tension bars to size where they meet the first course at the overhead arch, again allowing a few inches of overlap. Where tension bars overlap, use hog rings to secure. (See Mesh Detail.)

6.5 Pull the wire mesh tight in a downward direction and secure to every rib with tie wire on 18" centers.

6.6 If the mesh on the second course is loose or sags, then proceed with this step: The top few feet and the bottom few feet of the mesh (on the second course) may be loose. Gather one or two strands at the center rib and use hog rings to secure at every diamond. If still loose, repeat this step alternating from right to left of center. This does not necessarily mean this has to be done at every rib; only do so until tight.

6.7 Trim the bottom edge of the second course even with the top of the first course, allowing a one-diamond overlap.

6.8 Secure the two courses of mesh together with hog ringers every other diamond. Twist cut wire ends around the first course making sure no sharp wires are exposed. (See Mesh Detail)

6.9 Inspect complete backstop for loose hardware, fittings, and sharp wires. Repair as necessary. Place turf over main anchor footings.

7. Install Extension Mesh: (5' or 10' Extension)

7.1 Install a 5ft or 10ft tension bar in one end of the 2" x 9ga x 5ft or 10ft mesh. Roll mesh over the entire extension. Pull mesh tight and fasten with tension bands and bolts.

7.2 Attach mesh on overhead arch and overhead arch extension with tie wires every 12".

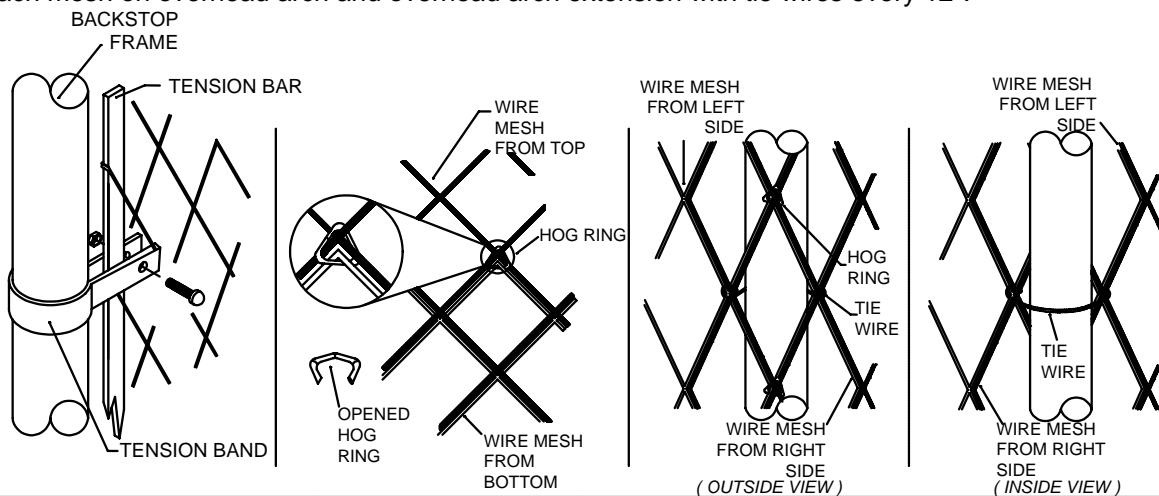

 <p>Patterson-Williams ATHLETIC MFG. CO. QUALITY ATHLETIC AND PARK EQUIPMENT SINCE 1919</p>	Date: 5-22-08	SPECIFICATION/INSTALLATION INSTRUCTIONS 40' PERPENDICULAR ARCH BACKSTOP
	Rev: A032812	
	Drawn: AMC	MODEL NO.
	Sheet: 6 of 9	1212-05 & 1212-10

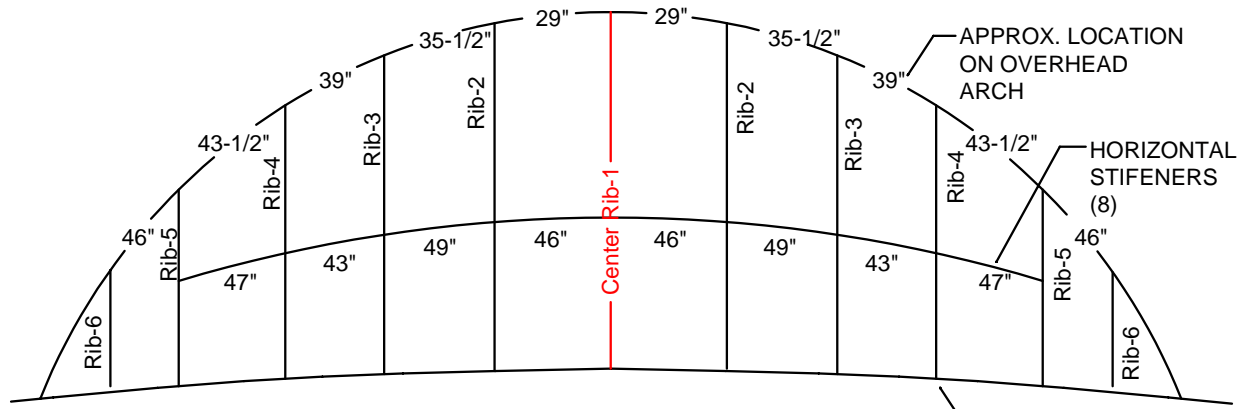

DETAIL-H

SPACING DETAIL

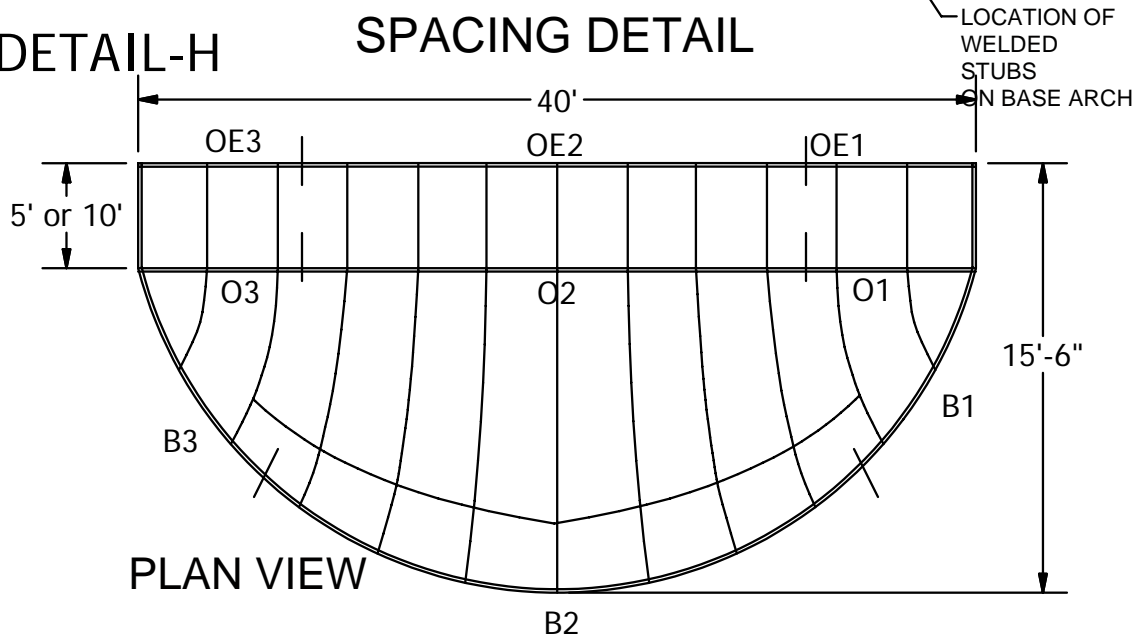

PLAN VIEW

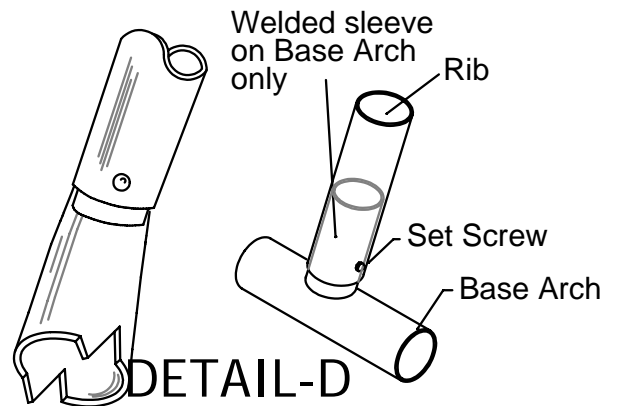
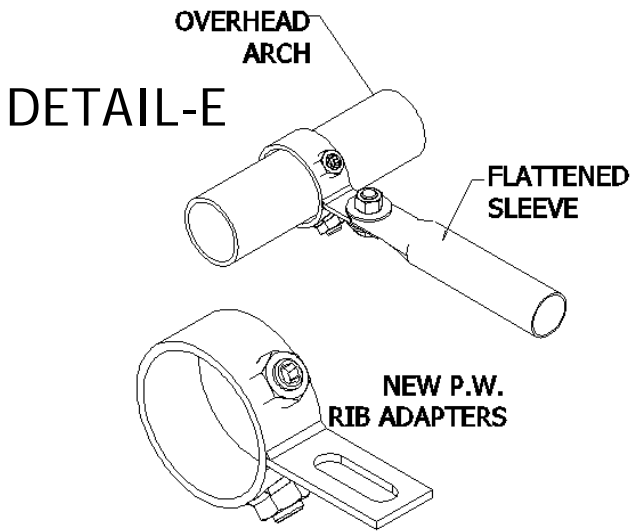

Date: 5-22-08
 Rev: A032812
 Drawn: AMC
 Sheet: 7 of 9

SPECIFICATION/INSTALLATION INSTRUCTIONS
 40' PERPENDICULAR ARCH BACKSTOP
 MODEL NO.
1212-05 & 1212-10

FOOTING DETAILS

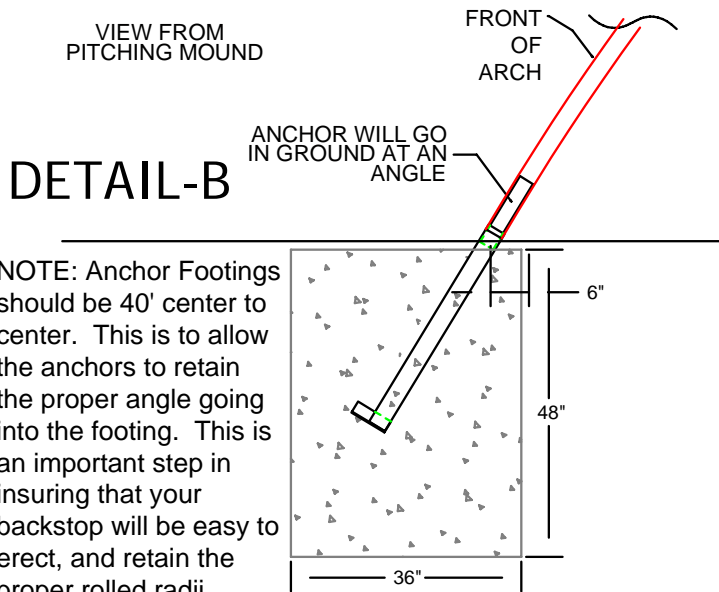
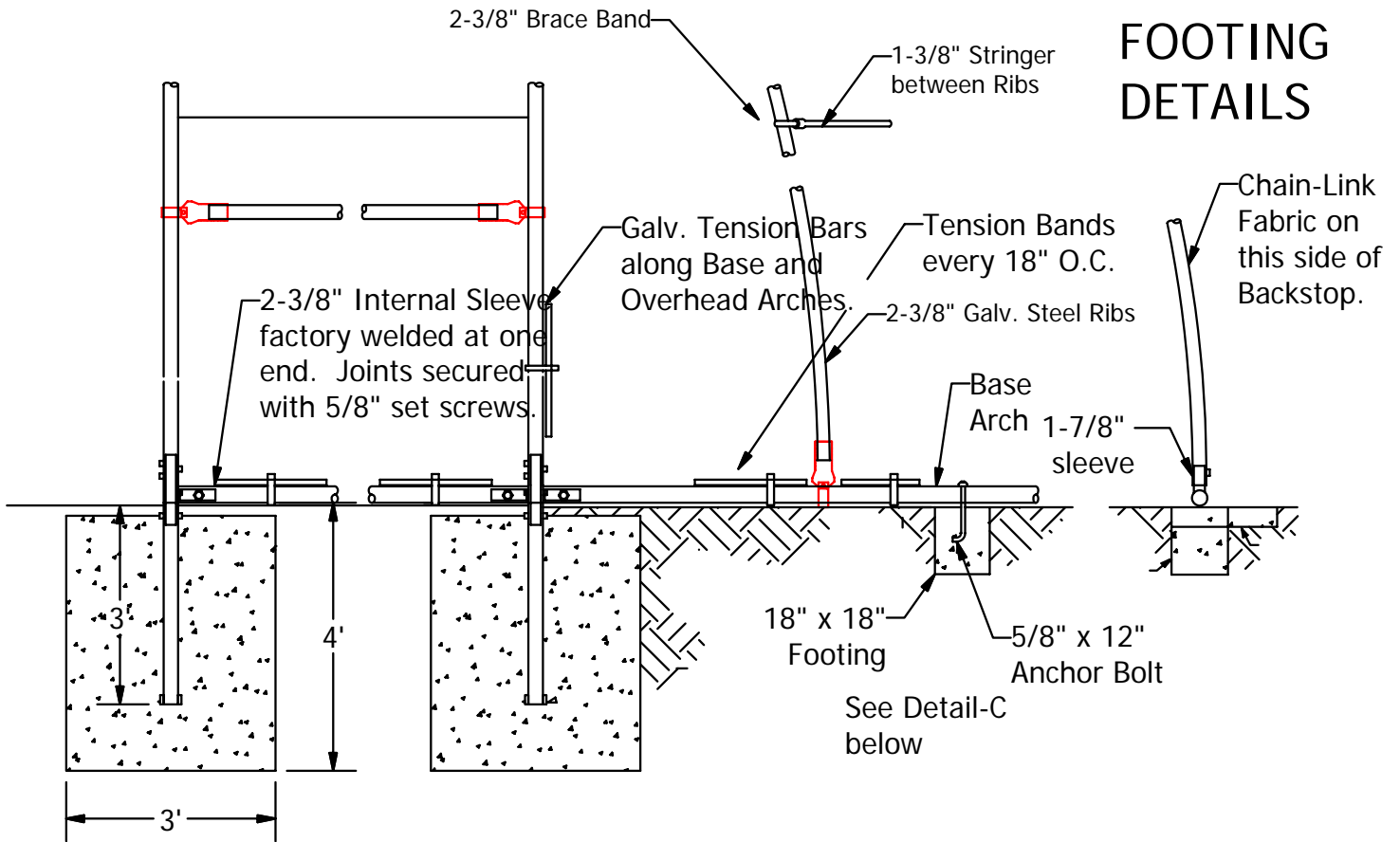

NOTE: Anchor Footings should be 40' center to center. This is to allow the anchors to retain the proper angle going into the footing. This is an important step in insuring that your backstop will be easy to erect, and retain the proper rolled radii.

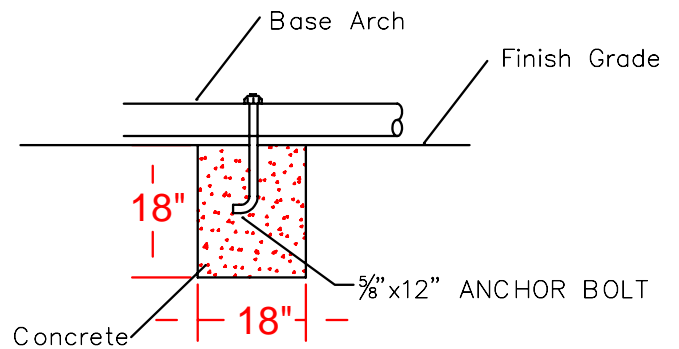

DETAIL-C



Date: 5-22-08
 Rev: A032812
 Drawn: AMC
 Sheet: 8 of 9

SPECIFICATION/INSTALLATION INSTRUCTIONS
 40' PERPENDICULAR ARCH BACKSTOP
 MODEL NO.
1212-05 & 1212-10

Description	Qty Per
	Unit
Left Base Arch - (B-1)	1
Center Base Arch - (B-2)	1
Right Base Arch (B-3)	1
Rib Assembly - (1)	1
Rib Assembly - (2)	2
Rib Assembly - (3)	2
Rib Assembly - (4)	2
Rib Assembly - (5)	2
Rib Assembly - (6)	2
Left Overhead Arch - (O-1)	1
Center Overhead Arch - (O-2) (2 Stubs)	1
Right Overhead Arch - (O-3)	1
Left Overhead Arch Extension (OE-1)	1
Center Overhead Arch Extension (OE-2)	1
Right Overhead Arch Extension (OE-3)	1
Extension Rib - 2-3/8" X (46"or106")	14
Extension Rib - 2-3/8" X (56-1/2"or116-1/2")	1
Base Extension - 2-7/8" X (56-1/2"or 116-1/2")	2
Stringer - Horiz. Stiffener - 43"	2
Stringer - Horiz. Stiffener - 46"	2
Stringer - Horiz. Stiffener - 47"	2
Stringer - Horiz. Stiffener - 49"	2
Backstop Anchor - (1st O/H Arch)	2
Backstop Anchor - (O/H Ext. Arch)	2
12' Tension Bars	2
8' Tension Bars	12
(5'or 10') Tension Bars	2
2" X 9 Gauge X (5'or10') Wire Mesh - (ft)	60
2" X 9 Gauge X 12' Wire Mesh - (ft)	100

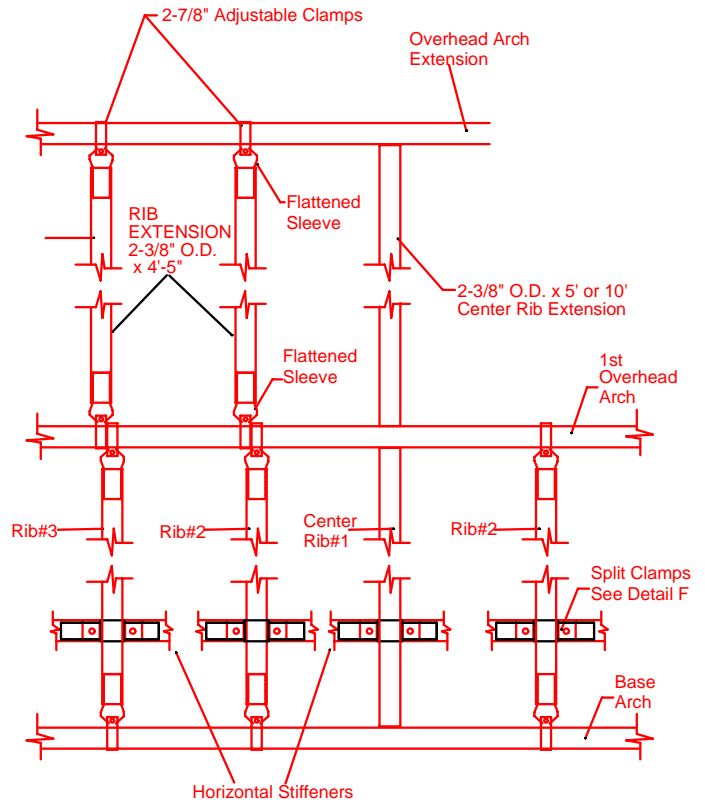

Component Description	Qty
2-7/8" Tension Band	90
2-3/8" Brace Band	2
2-7/8" HD PW Rib Collar	38
2-3/8" 180 Degree Split Clamp Band	14
Flattened Sleeves	38
5/8"-11 X 7/8" Socket Head Set Screw	80
Hog Ring #3 Galvanized - (lbs)	4
5/16"-18 X 1" Carriage Bolt	90
5/16"-18 X 1-1/4" Carriage Bolt	20
5/16"-18 Hex Nut	104
5/16" Split Washer	104
5/16" Flat Washer	104
3/8" X 1" Hex Bolt - (Grade 5)	38
3/8"-16 Lock Nut (Nylock)	38
3/8" Flat Washers	76
5/8"-11 X 12" Anchor Bolt	10
5/8"-11 Hex Nut	10
5/8" x 4" Hex Bolt	8
5/8" Nylock	8
5/8" Flat Washer	8
11 Gauge Tie Wire (lbs)	9



Date: 5-22-08
Rev: A110712
Drawn: AMC
Sheet: 9 of 9

SPECIFICATION/INSTALLATION INSTRUCTIONS
40' PERPENDICULAR ARCH BACKSTOP
MODEL NO.
1212-05 & 1212-10