

50' PERPENDICULAR ARCH BACKSTOP

□ MODEL #1218 - ARCH BACKSTOP 14'-6" H x 14'-6" D x 50' W (2,750 LBS)

OVERHEAD and BASE Arches: 2-7/8" O.D. galvanized steel.

Vertical Ribs: 2-3/8" O.D. galvanized steel. Ribs shall be formed to a smooth continuous radius throughout the entire length of each rib.

Flattened Sleeves: 1-7/8" O.D. galvanized steel, factory flattened and punched.

Horizontal Stiffeners: 1-3/8" O.D. galvanized steel, secured between vertical ribs with 2-way split clamps (galvanized), zinc plated 5/16" x 1-1/4" carriage bolts split washers and hex nuts. Where stiffeners connect to outside ribs, 3/4" wide galvanized steel brace bands shall be used along with 5/16" x 1" carriage bolts split washers and hex nuts. Any exposed threads to be destroyed by Installer.

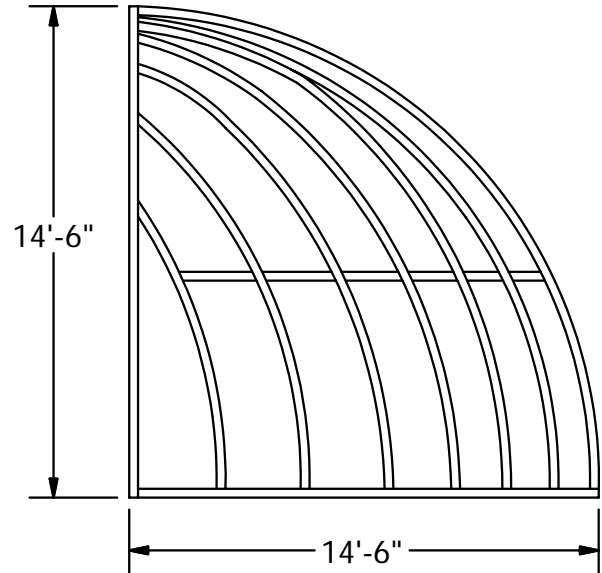

	Date: 5-22-08	SPECIFICATION/INSTALLATION INSTRUCTIONS
	Rev: A033012	
	Drawn: AMC	MODEL NO.
	Sheet: 1 of 9	MODEL NO. 1218-00

Main Footing Anchors: 2-7/8" O.D. galvanized steel, welded sleeves that fit into BASE and OVERHEAD arch ends (2-3/8" O.D. galvanized steel). Footing anchors shall extend 3 feet into footings and shall be welded at the bottom with one piece of 6" long angle (2" x 2" x 3/16") steel, to form an anchor in the concrete footing.

Anchor Bolts: 5/8" x 12" foundation bolts, extending throughout BASE arch and shall be evenly spaced between vertical ribs. Any exposed threads to be destroyed by Installer.

Tension Bars: 3/4" galvanized and shall be secured with galvanized tension bands spaced 18 inches on center and bolted with 5/16" x 1" zinc-plated carriage bolts lock washers and hex nuts. Threads to be destroyed by Installer 10 feet up on overhead arch. Tension bars shall be installed along inside overhead arch.

Chain Link Fabric: Fabric shall be 9-gauge on all models except top course shall be 11-gauge. It shall be installed horizontally in single lengths to outside of backstop using 12-gauge galvanized wire ties every 18 inches along vertical ribs. Edges shall be over-lapped a minimum of 1" to 2" and tied together with 9-gauge, #3 galvanized hog rings every 6 inches along seams. Fabric shall be pulled tight around curvature of backstop and shall be cut and trimmed in a neat and professional manner. Where wire is cut, exposed barbs shall be bent double to leave a knuckled edge, and should be cut along the rib.

PW Heavy Duty Rib Collars: Custom made 2-7/8" P.W. Heavy Duty Rib Adapter Collars.

Concrete Footing: Footings for OVERHEAD arch shall be 4' deep x 3' in wide. This is to allow the anchors to retain the proper angle going into the footing. this is an important step in insuring that your backstop will be easy to erect, and retain the proper rolled radii. Footings for BASE arch anchor bolts shall be 18" deep x 18" in. Concrete not included. See footing details on page 9.

Finish: All pipe and hardware is galvanized steel. All fasteners are zinc-plated except anchor bolts.

 <p>Patterson-Williams ATHLETIC MFG. CO. QUALITY ATHLETIC AND PARK EQUIPMENT SINCE 1919</p>	Date: 5-22-08	SPECIFICATION/INSTALLATION INSTRUCTIONS
	Rev: A033012	
	Drawn: AMC	MODEL NO.
	Sheet: 2 of 9	MODEL NO. 1218-00

GENERAL NOTES:

- I. Check materials received with the parts list (Page 9) to make sure that all components are included and to assure that the unit is complete.
- II. The site must be level not more than +/- 1" variation from mean elevation over the entire length and depth of the base arch.
- III. A construction-type forklift with a 20-foot boom capacity and scaffold will be necessary to assemble frames and attach wire mesh.
- IV. For maximum ball-capture, the overhead arch should be directly over home plate.
- V. The base and overhead arches are 2-7/8" O.D. and consist of three curved sections. The center sections of both the overhead and base arches have internal sleeves (2-3/8" O.D.) welded on each end and another external stub (1-7/8" O.D.) welded in the middle for center rib attachment. They are marked as follows:

Left end - BASE Arch B-1 Center - BASE Arch B-2 Right end - BASE Arch B-3
 Left end - OVERHEAD Arch O-1 Center - OVERHEAD Arch O-2 Right end - OVERHEAD Arch O-3

Extremely Important:

Before assembling the overhead arch:

- 1. On center arch (O2), slide three (3) rib adapter collars on each side of welded sleeve.
- 2. On left (O1) arch and right (O3) arch, slide two (2) rib adapter collars.
- 3. Secure sections with 5/8" x 4" Hex Bolts, Washer, and Nylocks.

DO NOT POUR CONCRETE UNTIL ENTIRE FRAME IS ASSEMBLED

PW has noted the size of the main anchor footings as a guide line, and asks that you check with your local permit authorizing personnel, or your architect before proceeding, as your area of the country might require larger footings.

Footing must be wide enough to allow anchor to be placed at the approx. angle shown (See Detail E page 9). The angle must be adjusted to form arch and maintain width of backstop. Anchor **MUST NOT** touch sides of footing.

PW has also noted this particular size, so the main anchors may swivel on the base arch to properly align with the overhead arch, the anchor must freely hang in footing and not touch sides of footing. When installing, place the anchors in the base arch, and leave them FINGER TIGHT ONLY, at this time. Place the overhead arch onto the main anchors and finger tighten at this time. This allows the overhead arch to settle in the proper angle and sphere to insure trouble free alignment with the ribs.

ONLY after assembling the entire arch, go back and tighten all set screws with proper sized allen wrenches at this time.

FRAME ASSEMBLY

1. Assemble the Base Arch:

- 1.1 Locate the three sections of the base arch. (B-1, B-2 & B-3) (Standing inside the base arch B-1 and B-3 are on your left and right respectively).
- 1.2 Begin by connecting the three sections (B-1, B-2 & B-3) of the base arch together using set screws provided. Make sure the end sleeves on B-2 are fully seated. Set in proper field location. Measure 50' outside to outside and adjust as necessary to conform to the 50' dimension. Mark the location of the main footings at each end of the base arch. Mark the 6 anchor bolt locations at each pre-drilled hole on B-1, B-2 and B-3.
- 1.3 Move base arch aside and dig footings. Main anchor footing dimensions are 36" wide x 48" deep. Note: MAIN ANCHOR FOOTINGS SHOULD BE DUG TO ACCOMODATE THE ANGLE OF THE ANCHORS. Center the anchors in footing hole. (See Detail B page 8)
- 1.4 Relocate base arch to match footing locations. Measure outside to outside on base arch ends again and hold 50' dimension. Stake rear of base arch to prevent sliding when installing overhead arch. Note: Footing sizes are based on average soil conditions. Loose and/or sandy soil is not average and footing sizes must be increased accordingly to meet local soil conditions.

 <p>Patterson-Williams <small>ATHLETIC MFG. CO.</small> <small>QUALITY ATHLETIC AND PARK EQUIPMENT SINCE 1919</small></p>	Date: 5-22-08	SPECIFICATION/INSTALLATION INSTRUCTIONS 50' PERPENDICULAR ARCH BACKSTOP
	Rev: A033012	
	Drawn: AMC	MODEL NO.
	Sheet: 3 of 9	MODEL NO. 1218-00

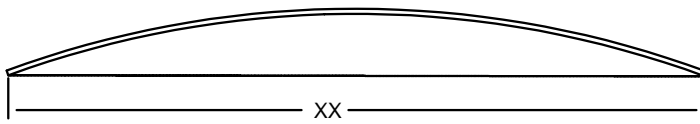

Note: Chord length measured in a straight line from one end of pipe to other end.

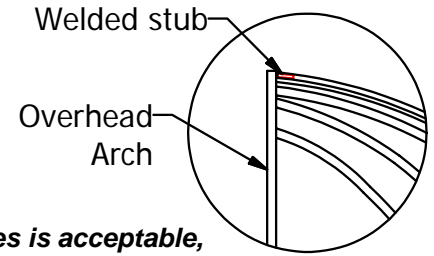

Before assembling the overhead arch: (Note: A slight variation in tolerances is acceptable, however, you should strive to maintain recommended dimensions as close as possible.)

1. On center arch (O2), slide three (3) rib collars on each side of welded sleeve.
2. On left (O1) arch and right (O3) arch, slide two (2) rib collars.
3. Secure sections with 5/8" x 4" Hex Bolts and Nylocks. Tighten before lifting overhead arch in the air.

2. Assemble the Overhead Arch:

- 2.1 Locate three sections of overhead arch (O-1, O-2 and O-3) and lay them on the ground in front of and directly opposite the base arch. (Standing inside the overhead arch) O-1 and O-3 will be on your left and right respectively). Make sure end sleeves on O-2 are fully seated. Use 5/8" x 4" Hex Bolts, washers & Nylocks to join arch sections together.
- 2.2 Raise assembled overhead arch into position using a forklift. Insert main footing anchors) into both ends of base arch. Lower the overhead arch onto main footing anchors until fully seated. Leave forklift in position to support the overhead arch until vertical ribs are installed.
- 2.3 At connecting locations on the main footing anchors use set screws to hold in place. until entire frame is assembled.

CRITICAL NOTE: AFTER OVERHEAD ARCH, BASE ARCH, AND RIB#1 IS UP, STOP TO VERIFY OVERALL MEASUREMENTS (WIDTH, HEIGHT, AND DEPTH INCLUDING VISUAL INSPECTION OF ALIGNMENT) BEFORE PROCEEDING. USE A RACHET STRAP TIED AT EACH END OF THE BASE ARCH TO KEEP WIDTH DIMENSION IN PLACE UNTIL FRAME IS COMPLETELY ASSEMBLED.

3. Install Vertical Ribs:

- 3.1.1 All vertical ribs are marked with numbers and should be installed in this order. Rib #1 is the center fixed rib. Insert bottom of center rib onto welded stub on the base arch. Hold back overhead arch and insert the top of rib #1 onto stub of overhead arch. Make sure rib and sleeve are seated on overhead & base arch. Tighten set screws to hold in place.

Note: After Overhead Arch, Base Arch, and Rib #1 is up, STOP! and verify measurements (Width, Height, and Depth) and also check side view to verify arch is perpendicular to field before proceeding.

- 3.1.2 Horizontal stiffeners are used between the ribs. There are different lengths of horizontal stiffeners. See Clamp Spacing Detail C on page 7 for correct location of each stiffener. Assemble one split half clamp on rib #1 using 5/16" x 1-1/4" carriage bolts, split washers and hexnuts and attach stiffener (57") to each side of clamp. Slide stiffeners and clamps up the rib to approximately 6' above finish grade. Only tighten bolts enough to hold in place.
- 3.1.3 To install remaining ribs, locate the rib adapter collars that were slid onto the overhead arches done before step 1. Locate the flattened end sleeves. (See Detail page 7) Insert flattened sleeve into top of rib #2 and assemble to rib collar.
- 3.1.4 In an alternating sequence, install the remaining ribs, 2, 3, 4, 5, & 6 installing one rib to each side of previous rib. (See Detail page 8) Do not tighten bolts fully tight until all stiffeners and clamps are in place.
- 3.1.5 Attach ribs #6 to top and bottom arches and use stiffeners (see detail page 8) to hold them in place. Use 2-3/8" brace bands on end of stiffener. Adjust ribs and stiffeners as needed for horizontal and vertical continuous curved appearance.
- 3.1.6 Make sure all sleeved joints are seated and proceed to tighten all bolts and set screws.
- 3.1.7 Install anchor bolts and nuts in the holes on base arch. Thread nuts on anchor bolts until two threads are protruding out of nut. Make sure the anchors are centered in footing holes. (See Detail D page 9)

NOTE: BEFORE CONTINUING, PERFORM A VISUAL INSPECTION. CONFIRM THAT THE OVERHEAD ARCH IS STRAIGHT & PERPENDICULAR TO THE BASE ARCH, AND THAT THE RIBS FORM A SMOOTH CURVATURE ALONG THE BACK SIDE OF THE ARCH.

	Date: 5-22-08	SPECIFICATION/INSTALLATION INSTRUCTIONS
	Rev: A033012	
	Drawn: AMC	MODEL NO.
	Sheet: 4 of 9	MODEL NO. 1218-00

NOTE: BEFORE CONTINUING, PERFORM A VISUAL INSPECTION. CONFIRM THAT THE OVERHEAD ARCH IS STRAIGHT & PERPENDICULAR TO THE BASE ARCH, AND THAT THE RIBS FORM A SMOOTH CURVATURE ALONG THE BACK SIDE OF THE ARCH.

3.1.8 Check for overall frame alignment and adjust frame before pouring concrete. Pour concrete in the large main footing holes to within 2" of finished grade. (See Detail B page 8) Pour anchor bolt footings up to finished grade. Allow concrete to set for 3 days before completion of install. After footings have set cover main footings with dirt or turf. Note: Footing sizes are based on average soil conditions. Loose and/or sandy soil is not average and footing sizes must be increased accordingly to meet local soil conditions.

5) Installation of WIRE MESH (Mesh is installed in 2 courses):

- 5.1) 1st or Bottom Course: 2" - 9ga x 12' width 60' long. (Combine lengths of mesh to fit bottom course).
 - 5.1.1) Cut 10' off one roll and splice the two lengths of 12' 9ga mesh into one 60' length.
 - 5.1.2) Stand the wire up on edge and position on the outside of the frame so the bottom edge is flush with the bottom of the BASE arch, and so it is centered.
 - 5.1.3) Secure the mesh to the center rib only with tie-wire on 18" centers.
 - 5.1.4) Pull the mesh tight to each end. Trim the excess on the bias about 2" short of the OVERHEAD arch at both ends to allow room for tension bars and bands.
 - 5.1.5) Install one 12' tension bar in the mesh at each end (parallel to OVERHEAD arch) so the tops of the bars are flush with the top of the mesh. Where the bars do not fit through the mesh properly, the cut ends of the wire must be twisted around the bars to prevent unraveling of the mesh. Make sure there are no exposed sharp wires. (See Mesh Detail I page 7)
 - 5.1.6) Pull mesh as tight as possible, as it will save having extra work later.
 - 5.1.7) Install tension bands on 18" centers on the OVERHEAD arch up to the top of the mesh. Secure bands with 5/16" x 1" carriage bolts split washer and nuts with carriage heads facing outside.
 - 5.1.8) Tighten hardware securely.
 - 5.1.9) If the top few feet of the mesh are still loose or sag between ribs, then proceed with this step:
 - a) Starting at the center rib at the top of the mesh cut the mesh along the rib downward to about 12" above where the mesh is tight. NOTE: Never cut the mesh more than 12" below the stiffeners (1-3/8" O.D. pipe between the ribs).
 - b) Pull the mesh tight starting at the bottom of the cut working upward using hog rings to secure approximately every other diamond.
 - c) Cut away the excess (the usual amount of excess at the top is 4" to 6") allowing enough wire left to twist the cut ends together.
 - d) Use more hog rings and/or tie wire as necessary to completely secure the seam (see Mesh Detail I page 7).
 - e) If the top of the mesh is still loose or sags, repeat step 5.1.9 for each rib until it is tight. NOTE: This does not necessarily mean this needs to be done at every rib, only until tight. Work from center rib outward alternating right and left. At some of the outer ribs cutting may not be necessary but it may be necessary to gather one or two strands of mesh and secure with hog rings.
 - 5.1.10) Secure the mesh to all of the ribs with tie wire on 18" centers.

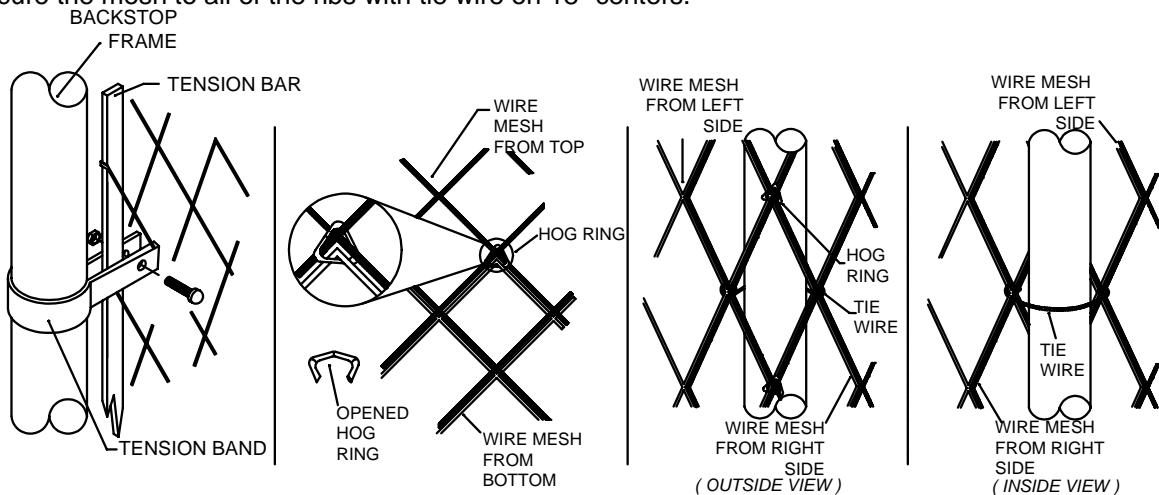

Date: 5-22-08
 Rev: A033012
 Drawn: AMC
 Sheet: 5 of 9

SPECIFICATION/INSTALLATION INSTRUCTIONS
 50' PERPENDICULAR ARCH BACKSTOP
 MODEL NO.
MODEL NO. 1218-00

- 5.1.11) Install the bottom 10' tension bars in the second diamond up from the bottom of the mesh. Feed the bars through the mesh starting at one end working to the opposite end.
- 5.1.12) Overlap the ends of the tension bars a few inches at the ends. The last tension bar must be cut to size so it is flush with the inside edge of the OVERHEAD arch. Note: The bars must be installed after the mesh is tight if not, the mesh will not conform to the shape of the backstop).
- 5.1.13) To install tension bands, it may be necessary to loosen nuts on anchor bolts and raise the BASE arch slightly so they will fit underneath. Install bands on 18" centers all along the BASE arch. Secure with 5/16" x 1" carriage bolts, split washer & nuts (with heads facing outside of the tension bars) along the BASE arch. Use hog rings to secure overlap of tension bars.
- 5.1.14) Tighten anchor bolt nuts securely so the BASE arch is in contact with the anchor bolt footings. Peen any excess threads to prevent removal.

5.2) 2nd Course: 2" - 9 ga x 12' width 40' long. (Combine lengths of mesh to fit next course)

5.2.2) Raise into position on frame and center. Align the center of the bottom edge with the top center edge of the first course over-lapping one diamond. At the ends of the second course, the bottom edges will overlap first course at each end. (See Mesh Detail page 5).

5.2.3) Secure the mesh to the center rib with tie wire on 18" centers. Pull mesh tight to each end. Trim the excess on the bias about 2" short of the OVERHEAD arch at both ends to allow room for tension bars and bands.

5.2.4) Install one 8' tension bar in the mesh at each end (parallel to OVERHEAD arch) so the bottoms of the bars overlap the top ends of the tension bars on the first course by 2 inches. Where the bars do not fit through the mesh properly, the cut ends of the wire must be twisted around the bars to prevent unraveling of the mesh. Make sure there are no exposed sharp wires (see Mesh Detail page 5).

5.2.5) Pull mesh tight as possible, as it will save having extra work later.

5.2.6) Install tension bands on 18" centers up to the top of the mesh. NOTE: Do not install tension bands beyond the top of the mesh until the third course is installed. Secure bands with 5/16" x 1" carriage bolts and nuts with heads facing outside.

5.2.7) Tighten hardware securely. Use hog rings to secure overlap of the tension bars.

5.2.8) If the mesh on the second course is loose or sags, proceed with this step:

- a) The top few feet and the bottom few feet of the mesh (on the second course) may be loose. Gather one or two strands at the center rib and use hog rings to secure at every diamond.
 - b) If still loose, repeat this step alternating from right to left of center. This does not necessarily mean this has to be done at every rib; only do so until tight.
 - c) Trim the second course of mesh along the bottom edge and at each end even with the top of the first course, allowing a one-diamond overlap (see Mesh Detail I page 5).
- 5.2.9) Secure the two courses of mesh together with hog rings every other diamond. Twist cut wire ends around the first course making sure no sharp wires are exposed (see Mesh Detail I page 5).
- 5.2.10) Secure the mesh to all of the ribs with tie-wire on 18" centers.

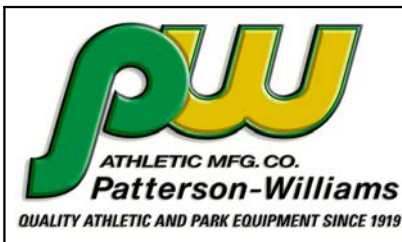
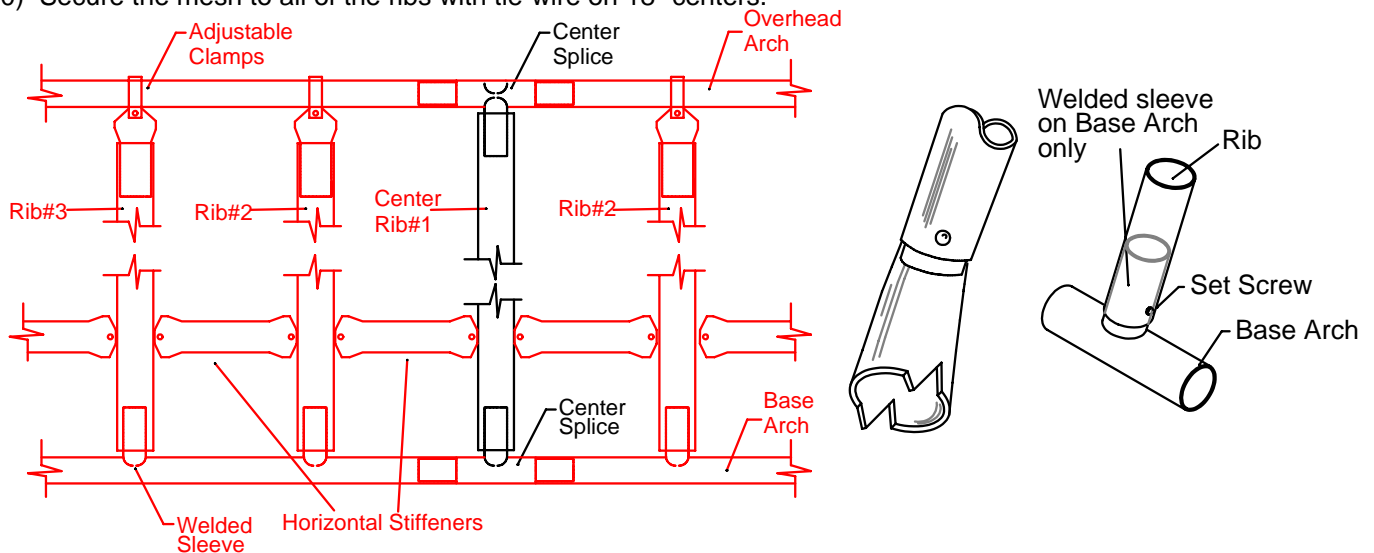

Date: 5-22-08
 Rev: A033012
 Drawn: AMC
 Sheet: 6 of 9

SPECIFICATION/INSTALLATION INSTRUCTIONS
 50' PERPENDICULAR ARCH BACKSTOP
 MODEL NO.
MODEL NO. 1218-00

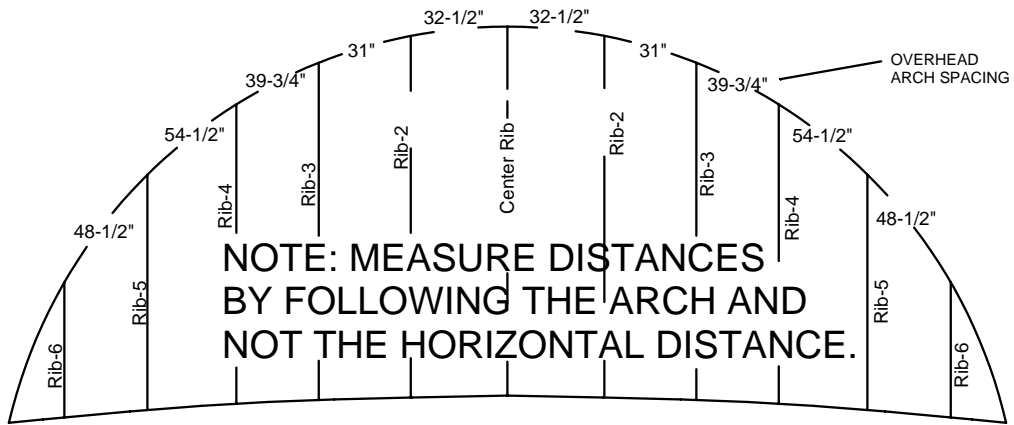
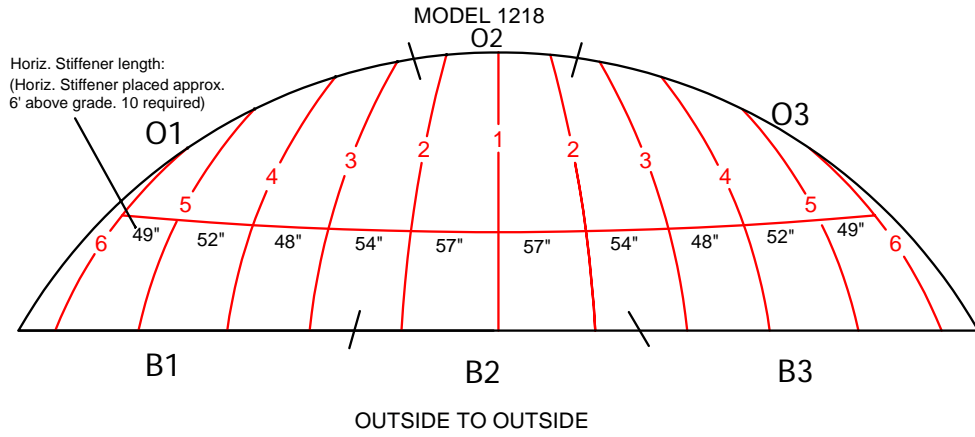

CLAMP SPACING DETAIL "C"

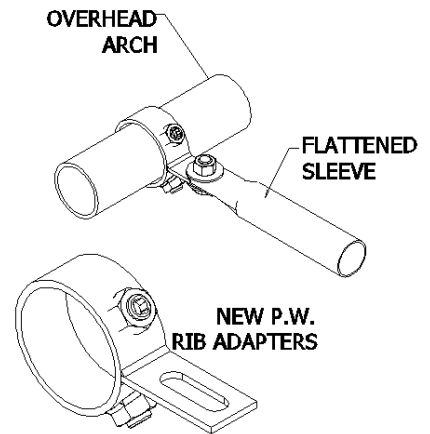
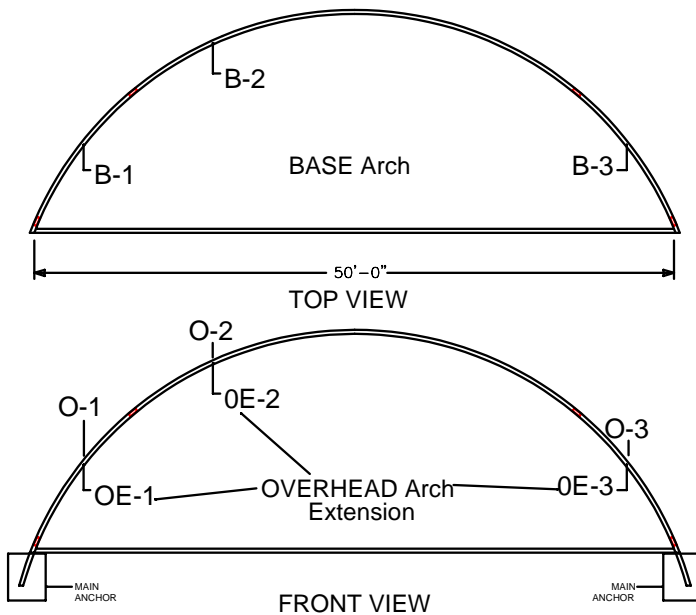

Date: 5-22-08
 Rev: A033012
 Drawn: AMC
 Sheet: 7 of 9

SPECIFICATION/INSTALLATION INSTRUCTIONS

50' PERPENDICULAR ARCH BACKSTOP

MODEL NO.
MODEL NO. 1218-00

DETAIL-B

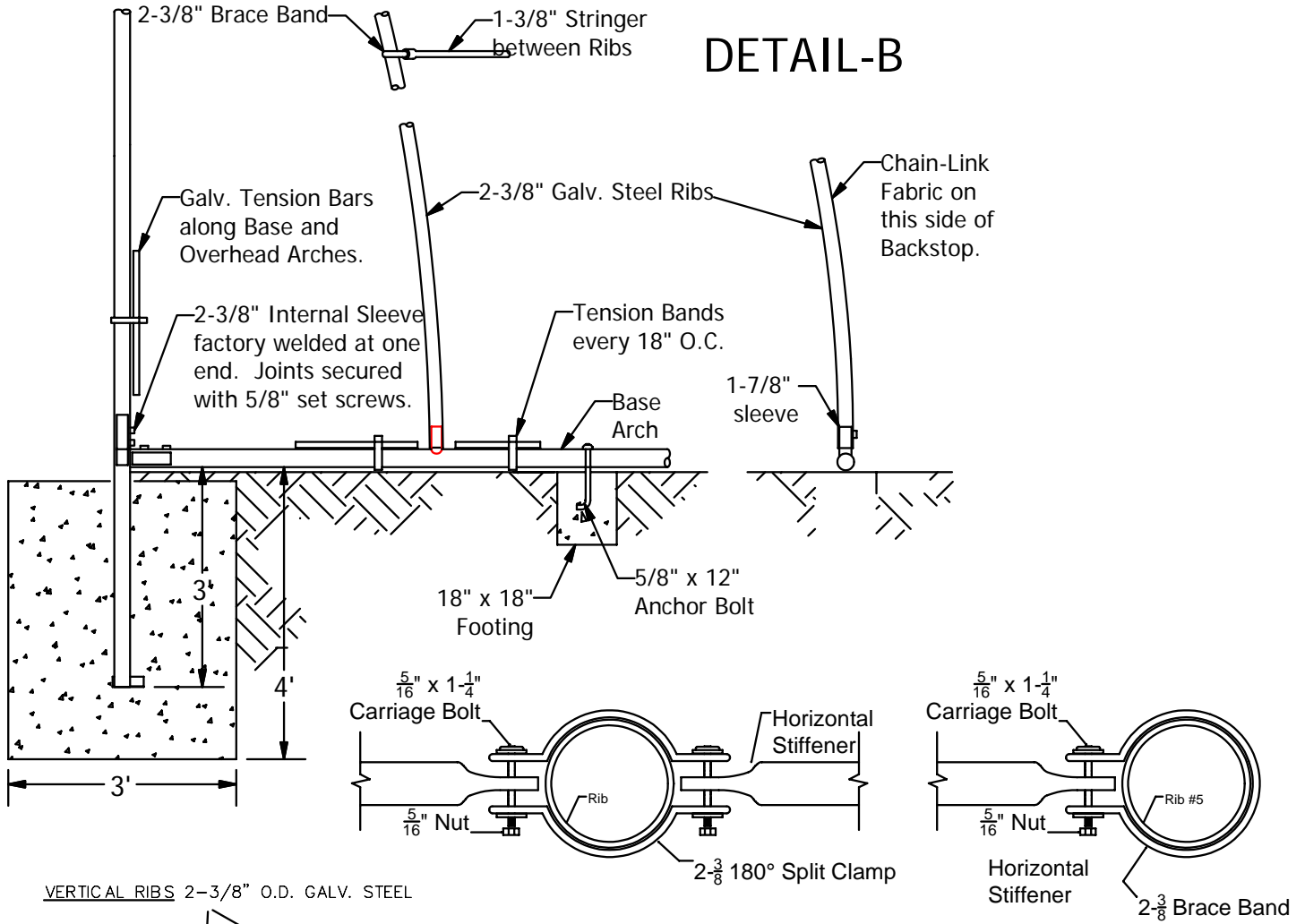

VERTICAL RIBS 2-3/8" O.D. GALV. STEEL

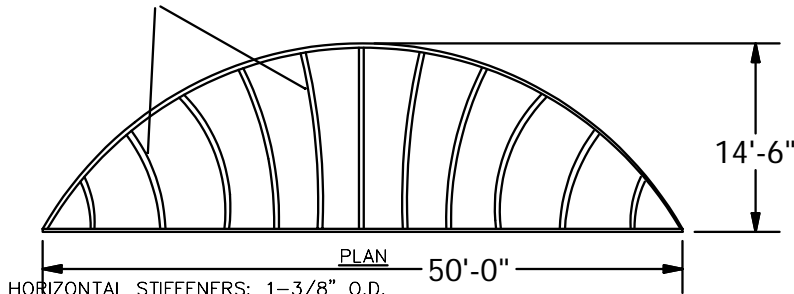

HORIZONTAL STIFFENERS: 1-3/8" O.D. GALV. STEEL

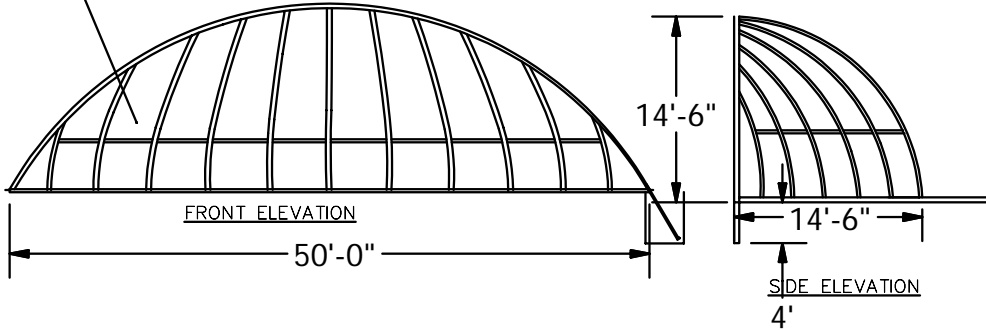

Date: 5-22-08
 Rev: A011813
 Drawn: AMC
 Sheet: 8 of 9

SPECIFICATION/INSTALLATION INSTRUCTIONS

50' PERPENDICULAR ARCH BACKSTOP

MODEL NO.
MODEL NO. 1218-00

VIEW FROM
PITCHING MOUND

FRONT
OF
ARCH

ANCHOR WILL GO
IN GROUND AT AN
ANGLE

DETAIL-E

NOTE: Anchor Footings should be 50' center to center. This is to allow the anchors to retain the proper angle going into the footing. This is an important step in insuring that your backstop will be easy to erect, and retain the proper rolled radii.

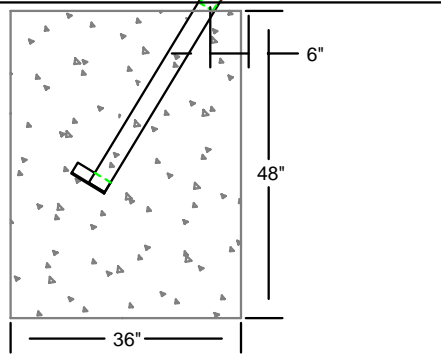

DETAIL-D

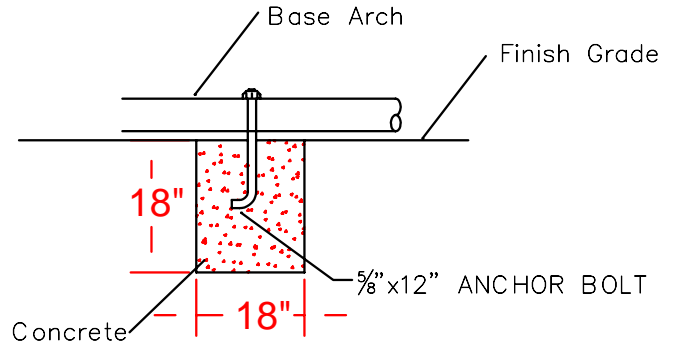

Description	Unit
LEFT BASE ARCH (B-1) (2-7/8" O.D.)	1
CENTER BASE ARCH (B-2) (2-7/8" O.D.)	1
RIGHT BASE ARCH (B-3) (2-7/8" O.D.)	1
Rib Assembly - (1) (2-3/8" O.D.)	1
Rib Assembly - (2) (2-3/8" O.D.)	2
Rib Assembly - (3) (2-3/8" O.D.)	2
Rib Assembly - (4) (2-3/8" O.D.)	2
Rib Assembly - (5) (2-3/8" O.D.)	2
Rib Assembly - (6) (2-3/8" O.D.)	2
Left Overhead Arch (O-1) (2-7/8" O.D.)	1
Center Overhead Arch (O-2) (2-7/8" O.D.)	1
Right Overhead Arch (O-3) (2-7/8" O.D.)	1
Horizontal Stiffener - (48")	2
Horizontal Stiffener - (49")	2
Horizontal Stiffener - (52")	2
Horizontal Stiffener - (54")	2
Horizontal Stiffener - (57")	2
Backstop Anchor	2
12' Tension Bar	2
8' Tension Bar	13
2" x 9 Gauge x 12' Wire Mesh - (ft)	100

Component Description	Qty
Flattened Sleeve	10
2-7/8" HD PW Adjustable Collar	10
2-7/8" Tension Band	81
3/8" x 1" Hex Head Grade 5 Bolt	10
3/8" Flat Washers	20
3/8" -16 Lock Nut (Nylock)	10
2-3/8" Brace Band	2
2-3/8" 180 Degree Split Clamp Band(ea)	18
Hog Ring #3 Galvanized - (lbs)	4
5/16" x 1" Carriage Bolt	81
5/16"-18 x 1-1/4" Carriage Bolt	18
5/16"-18 Hex Nut	99
5/16" Flat Washer	99
5/16" Split Washer	99
5/8"-11 x 12" Anchor Bolt	10
5/8" - 11 Hex Nut	10
5/8" x 4" Hex Bolt (Overhead Arch)	4
5/8" Nylock (Overhead Arch)	4
5/8" Flat Washer (Overhead Arch)	8
11 Gauge Tie Wire (lbs)	8
5/8" Socket Head Set Screws	34
3/8" Socket Head Set Screws	20



Date: 5-22-08
 Rev: A110912
 Drawn: AMC
 Sheet: 9 of 9

SPECIFICATION/INSTALLATION INSTRUCTIONS

50' PERPENDICULAR ARCH BACKSTOP

MODEL NO.

MODEL NO. 1218-00