

# PERMANENT HOODED BACKSTOP INSTALLATION INSTRUCTIONS MODEL #1233-02

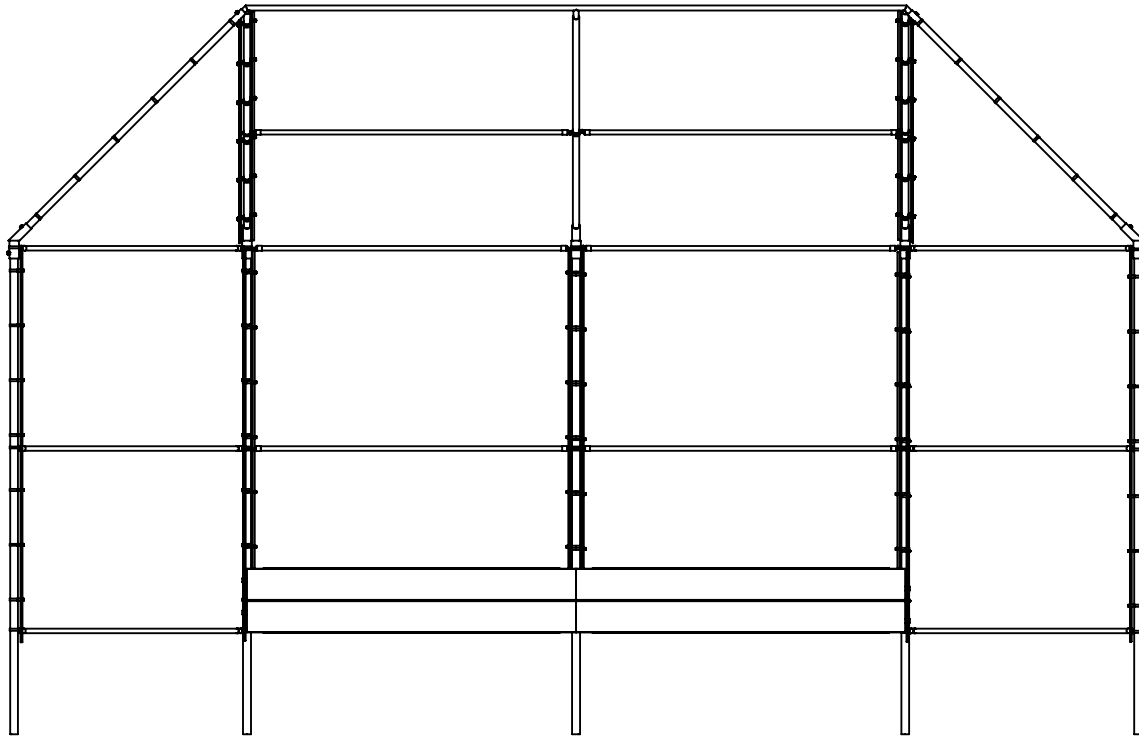

Description: A heavy duty backstop shipped unassembled with all parts and instructions for quick assembly.

Materials: All pipe and fittings are galvanized steel. Sizes given are outside diameter and exposed ends are capped. Planking is recycled plastic.

### Specifications

Vertical Posts  
Horizontal Rails  
Hood Angle Posts  
RCP

Size  
2-7/8"  
1-5/8"  
2-3/8"  
2" x 12"



Date: 3/9/23  
Rev:  
Drawn: CW  
Sheet: 1 of 8

**PRODUCT NAME**  
**HOODED BACKSTOP**  
MODEL NO.  
**1233-02-SPEC**

ITEM NO.	PART NUMBER	DESCRIPTION	QTY.
1	ASA-0501-1230-G	HOOD ANGLE $\phi$ 2-3/8" ASSEMBLY	5
2	RT-001-1234-180-G	LEG POST 2-7/8" DIA. x 11GA	5
3	HWCB5161	5/16"-18 x 1" CARRIAGE BOLT	120
4	HWFLWA516	5/16" USS FLAT WASHER	120
5	HWLN516	5/16"-18 LOCK NUT	120
6	VCIRAILEND158	1-5/8 ID RAIL END	28
7	VCIBB238	2-3/8" BRACE BAND	4
8	VCIBB278	2-7/8" BRACE BAND	16
9	HWSC581	5/8" SS SET SCREW	15
10	VCITEN238	2-3/8" TENSION BAND	36
11	VCITBAR10	10' x 3/4" TENSION BAR (118")	6
12	ASA-0502-1230-G	HOOD CROWN ASSEMBLY	1
13	VCIRP21210GRN	2" x 12" x 120" RCP Plank	4
14	BSPLANKANGLE	2" x 2" ANGLE 108" LONG PLANK CAP	4
15	BSPLKSTRAP	ALUMINUM MESH ATTACHMENT BAR	4
16	BS2PLKANG	CENTER PLANK SUPPORT	2
17	HWSSLS14112	1/4" WOOD SCREW 1-1/2" LONG	52
18	HWSC3858	3/8"-16 x 5/8" SET SCREW	8
19	RT-003-1234-112.5-G	STIFFENER 1.625 DIA.	10
20	CI12ELB1	HOODED BACKSTOP ELBOW FITTING	5
21	VCIBB35	3-1/2" BRACE BAND	8
22	RT-008-1234-112-G	STIFFENER 1.625 DIA.	4
23	VCITEN278	2-7/8" TENSION BAND	56
24	VCITBAR12	12' x 3/4" TENSION BAR	8
25	2PlankAssembly278	2 PLANK MOUNTING ASSEMBLY	4
26	RMMESHGA21110	2" x 11GA x 10' GAL MESH	40'
27	RMMESHGA2912	2" x 9GA x 12' GAL MESH	40'
28	VCITIEWIRE	TIE DOWN 10-1/2" x 12GA WITH HOOK	185

	Date:	3/9/23	PRODUCT NAME
	Rev:		<b>HOODED BACKSTOP</b>
	Drawn:	CW	MODEL NO.
	Sheet:	2 of 8	<b>1233-02-SPEC</b>

# FOOTING DETAIL

- 1) Determine the location of the backstop so the rear panel is perpendicular to a line running from 2nd base through home plate and the wings are parallel with the sides of the diamond.
- 2) Dig holes according to Footing Plan below and Footing Detail. Place all the posts in the holes resting on the blocks. Each post shall be 12'-0" above ground and 10'-0" on center. Place a horizontal stiffener on the ground between each of the posts. Place a rail end fitting on each end of the stiffeners. Place a brace band over each post adjacent to each rail end fitting. Bolt the rail end fitting to the corresponding brace band. Make sure the horizontal stiffeners fit into the rail end fittings at least 1".

**NOTE: All carriage bolt heads are facing the playing field.**

- 3) With the proper spacing established, plumb all the posts and pour the concrete footings up to 2" of finish grade and let set for three days before removal of bracing.

**NOTE: Footing sizes are based on the assumed soil bearing pressures from IBC 1807.**

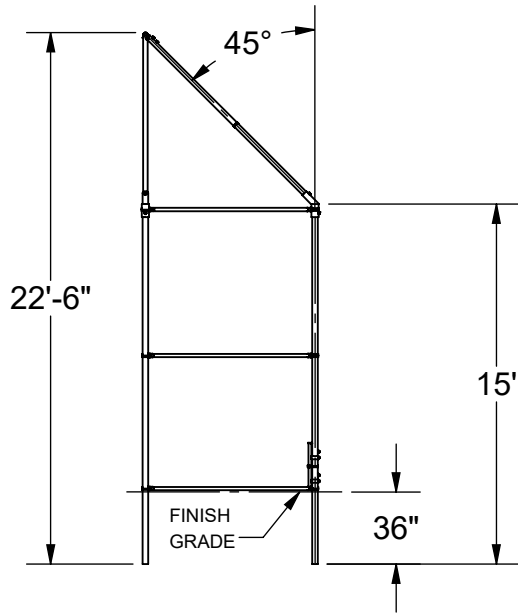

**SIDE VIEW**

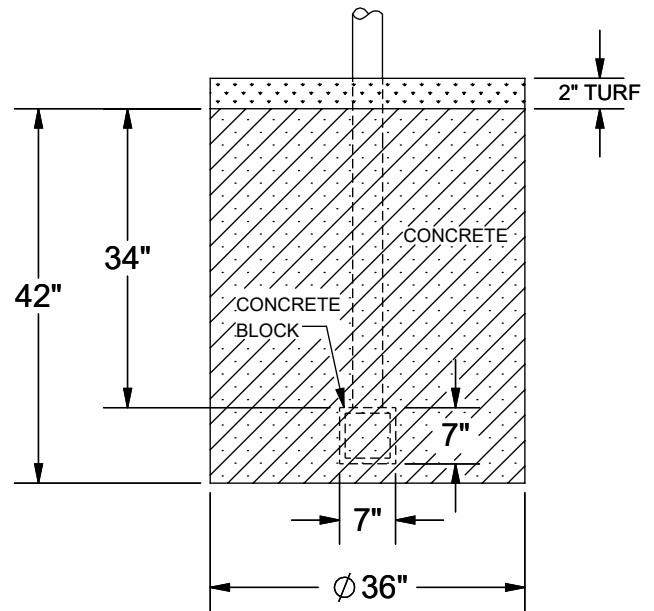

**FOOTING DETAIL**

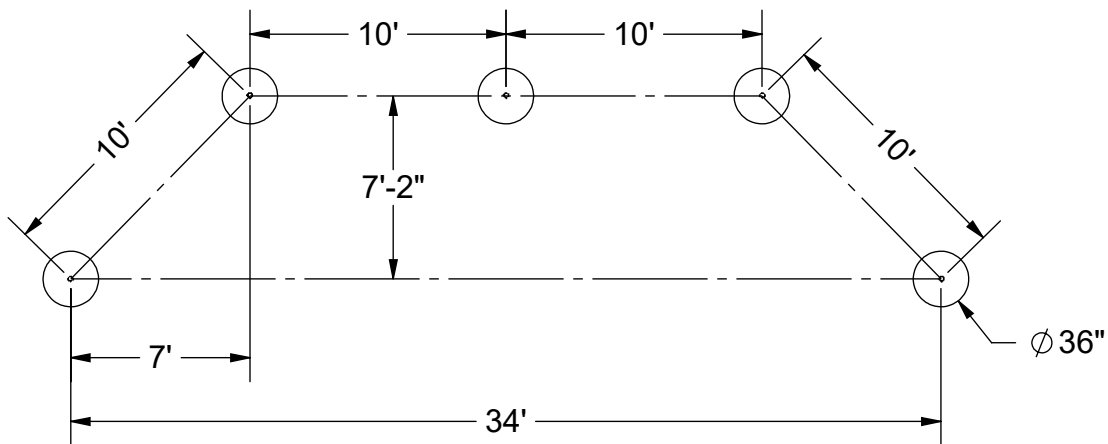

**FOOTING DIMENSIONS**

<p>ATHLETIC MFG. CO.</p>	Date: 3/9/23	PRODUCT NAME
	Rev:	HOODED BACKSTOP
	Drawn: CW	MODEL NO.
	Sheet: 3 of 8	1233-02-SPEC

# INSTALLATION INSTRUCTIONS

4) Check materials received with the BOM to make sure that all components are included and to assure that the unit is complete.

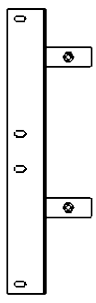

2PLANKASSEMBLY278

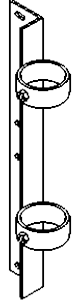

BS2PLKANG

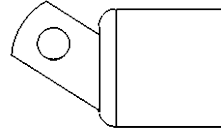

VCIRAIEND158

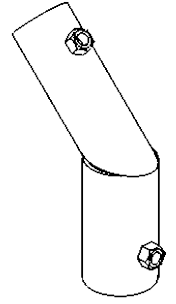

C112ELB1

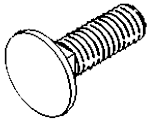

HWCB5161



HWFLWA516

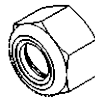

HWLN516

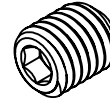

HWSC3858  
/HWSC581



HWSSLS14112



VCITBAR10/VCITBAR12

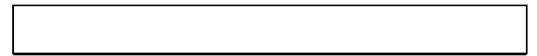

VCIRP21210GRN

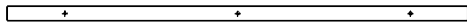

BSPLKSTRAP

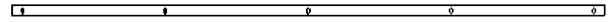

BSPLANKANGLE

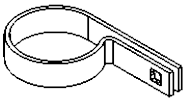

VCITEN238



VCIBB238

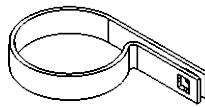

VCITEN278

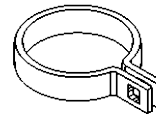

VCIBB278

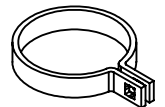

VCIBB35



Date: 3/9/23  
 Rev:  
 Drawn: CW  
 Sheet: 4 of 8

PRODUCT NAME  
**HOODED BACKSTOP**  
 MODEL NO.  
**1233-02-SPEC**

# INSTALLATION GUIDE

- 5) RC PLANK PREPARATION: Take the (4) RCP planks and trim them down to 120" (10') long. These planks will be the back wall sections.
- 6) Take all (4) planks and lay them on the ground or saw horses in front of the backstop. Locate the Center Plank Supports and 2 Plank Assemblies and put them on top of the evenly spaced planks. Center the slots evenly over the (4) planks with a 1/4" gap between planks. Once the spacing matches the view below, clamp the plates and pre-drill the holes before attaching the wood screws. Repeat this step for all the sections. **NOTE: the ends of some of the RCP planks may need to be chamfered to accomodate the tension bands.**
- 7) After the planks are installed, attach the 2" x 2" Plank Cap on the top and bottom of the planks, centering them between the 2 Plank Assemblies. Attach the mesh to the front side of the posts making sure the mesh goes behind the Plank Caps. Notch the mesh covering the Center Plank Supports. Install the Mesh Attachment Bar with wood screws to secure the mesh to the back side of the planks.

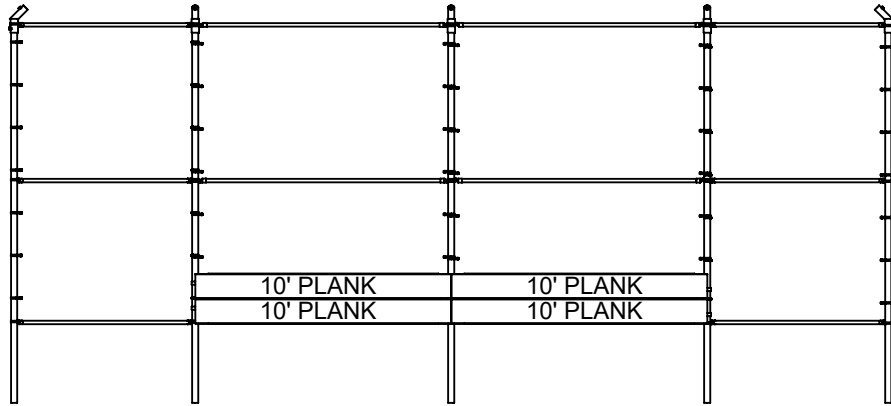

FRONT VIEW  
PLANK ASSEMBLY

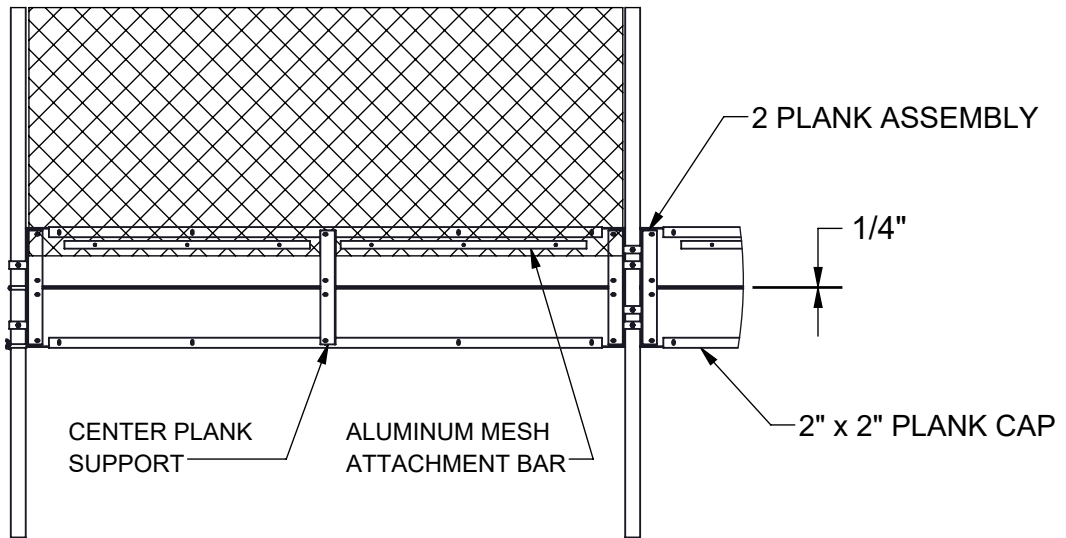

REAR VIEW  
PLANK ASSEMBLY

 <p>ATHLETIC MFG. CO.</p>	Date: 3/9/23	PRODUCT NAME
	Rev:	HOODED BACKSTOP
	Drawn: CW	MODEL NO.
	Sheet: 5 of 8	1233-02-SPEC

# INSTALLATION INSTRUCTIONS

8) Put the entire Backstop together, starting at the top and working from left to right.

Slide Brace Bands (8) (21), Tension Bands (23) and Hooded Backstop Elbow Fittings (20) onto the vertical posts.

TOWARD HOME PLATE

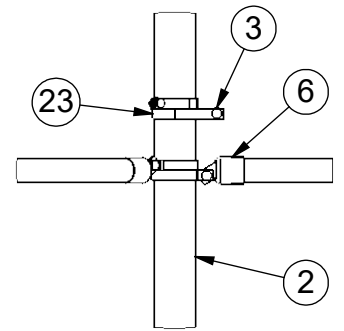
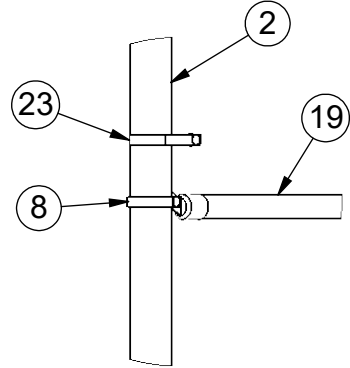
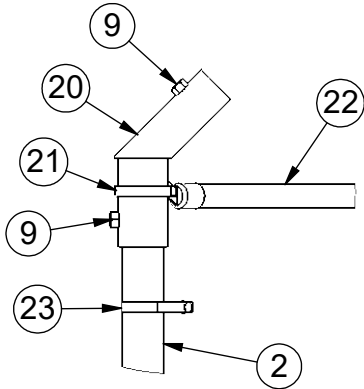
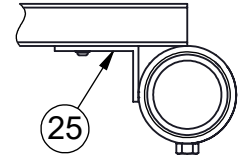
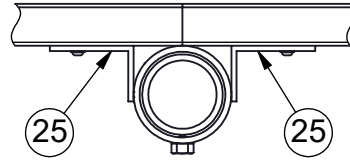
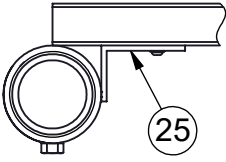

DETAIL A

DETAIL B

DETAIL C

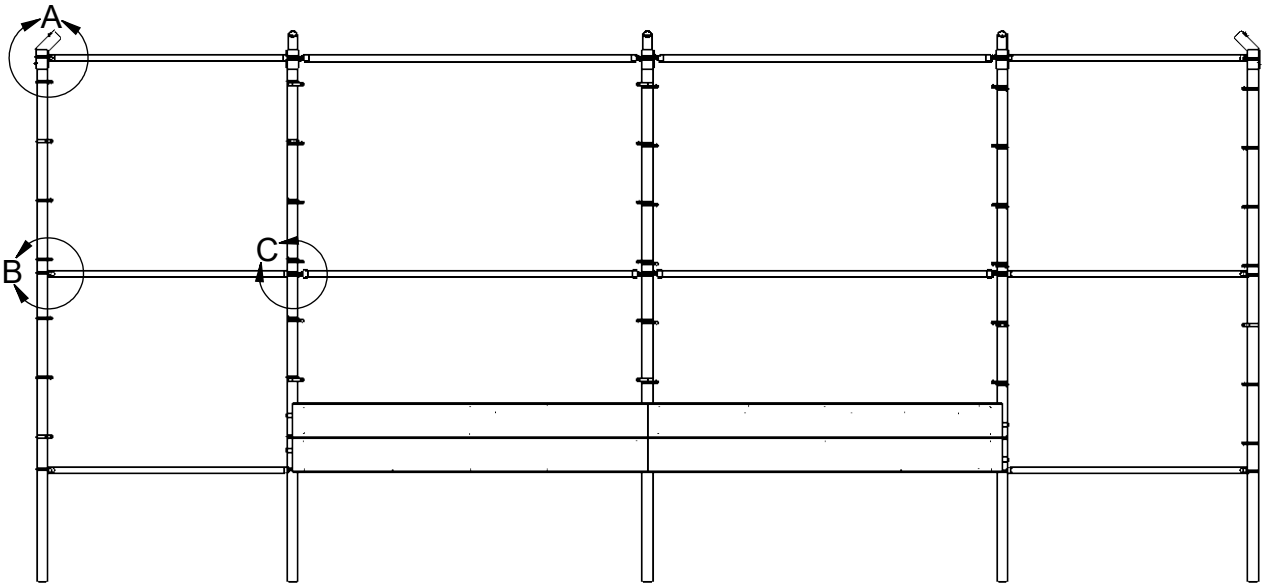

FRONT VIEW  
POSTS AND HORIZONTAL RAILS



Date: 3/9/23	PRODUCT NAME
Rev:	<b>HOODED BACKSTOP</b>
Drawn: CW	MODEL NO.
Sheet: 6 of 8	<b>1233-02-SPEC</b>

# INSTALLATION INSTRUCTIONS

9) Start building the hood by working from left to right. Slide the 2-3/8" Tension Bands (10) onto the Hood Angle Assemblies (1) with (6) on the outer angle and (12) on the inner angle, (spaced 18" to 20" apart) repeating for the right side. Install the 2-3/8" Brace Bands (7) onto the Hood Angle Assemblies (1) as shown in Detail F. Install the Stiffeners (19) as shown below. The Stiffeners use 2-3/8" Brace Bands, 1-5/8" Rail Ends with 5/16"-18 x 1" Carriage Bolts, 5/16" Flat Washers and 5/16" Lock Nuts.

10) Install the Hood Crown Assembly (12) by sliding the five stubs into the five Hood Angle Assemblies. Install the 5/8" set screws into the hex nuts on the Hood Angle Assemblies and tighten.

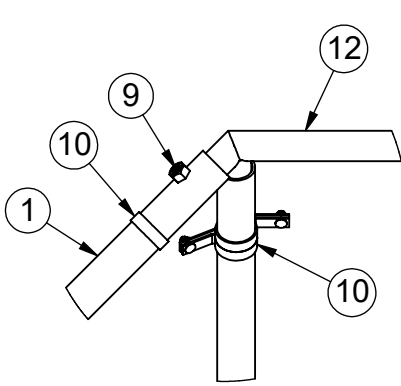

DETAIL D

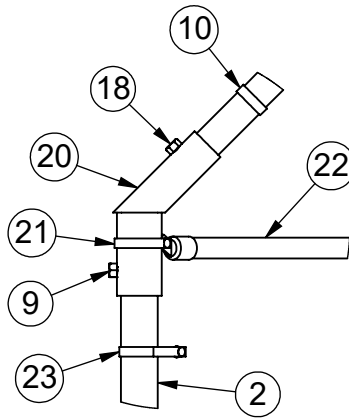

DETAIL E

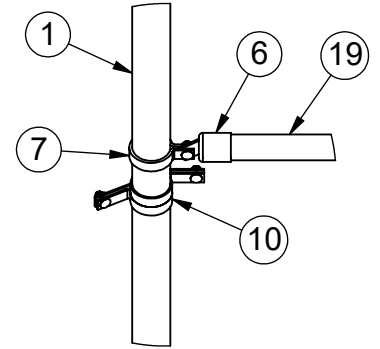

DETAIL F

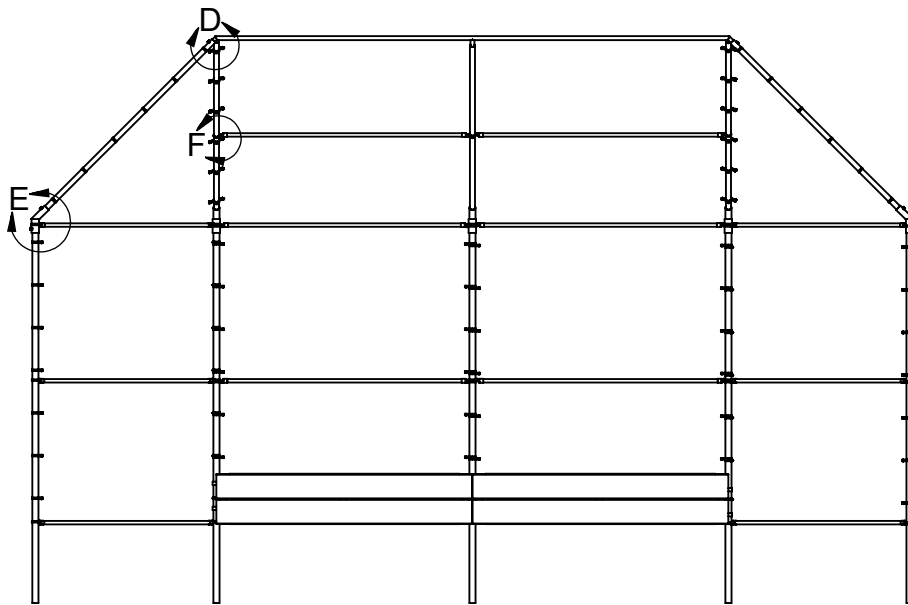

FRONT VIEW  
HOOD ASSEMBLY

 <p>ATHLETIC MFG. CO.</p>	Date: 3/9/23	PRODUCT NAME
	Rev:	HOODED BACKSTOP
	Drawn: CW	MODEL NO.
	Sheet: 7 of 8	1233-02-SPEC

## **INSTALLATION INSTRUCTIONS**

**MESH INSTALLATION:** Separate the wire mesh as the heavier material (9 GA) is to be used along the rear panel and the wings while the lighter material (11 GA) is to be used on the hood. The mesh is cut to the approximate size and shipped in rolls.

1. Cut four pieces of (9 GA x 12' mesh) 10 feet wide to be installed between the vertical posts of the rear panel and the wings. Attach each piece of mesh using one 12 foot tension bar on each end of the mesh along with the tension bands and bolts provided. Place tension bands on 18 to 20 inch centers. The mesh is placed against the playing field side of the backstop with the tension bands parallel and adjacent to the vertical posts. The mesh must be tight; remove strands as necessary to achieve the proper tension.
2. Secure the mesh to the top, center and bottom of the horizontal rails with tie wires every 12 inches.
3. Cut one piece of (11 GA x 10' mesh) 20' wide. Attach the mesh to the rear of the hood panel using one tension bar on each end of the piece along with tension bands and hardware provided. Tension bands should be used on 18 to 20 inch centers. The mesh must be tight; remove strands as necessary to achieve the proper tension.
4. Secure the mesh to the top, center and bottom of the horizontal rails of the hood supports with tie wires every 12".
5. Cut two 10' long pieces of 11 GA mesh into two triangles to cover the remainder of the hooded area. Use the hood as a template.
6. Install two 10' tension bars in each triangular mesh piece along the two edges where the wire ends are NOT twisted together (knuckled salvage edge). Attach the mesh in the corners of the hood so the edge of the mesh without the tension bar is along the horizontal rail. Use tension bands on 18" to 20" centers to secure to the hood supports. The mesh must be tight; remove one to two strands as necessary to achieve the proper tension.
7. Pull the bottoms of each triangular mesh piece tight and secure with tie wires every 8" to the horizontal rails.
8. Inspect for loose hardware and tighten as necessary. Also look for sharp wires and either cut or turn back into the fabric as necessary.
9. Replace the turf to cover the exposed tops of the footings.

	Date: 3/9/23	PRODUCT NAME
	Rev:	<b>HOODED BACKSTOP</b>
	Drawn: CW	MODEL NO.
	Sheet: 8 of 8	<b>1233-02-SPEC</b>