

# Permanent Hooded Backstop

MODEL #1235-00 Front Height: 19'-6" H; Front Width: 54'; with no Planks (2650 lbs)

Frames Available Standard as:  
Galvanized or Powder Coated

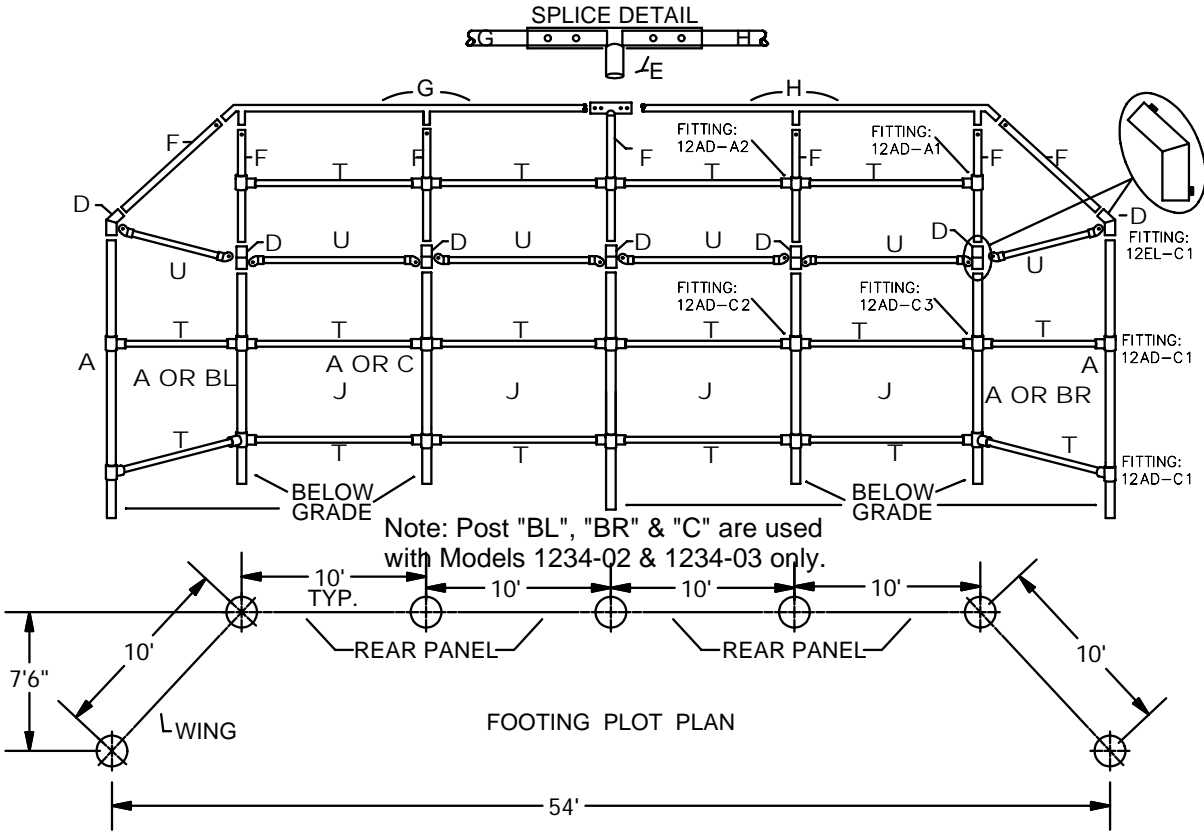

### Dimensions Model 1235

Front Opening: 19'-6" H x 54' W  
 Rear Opening: 12' H x 40' W  
 Side Panels: 12' H x 10' W  
 Front to Back: 7'-6"

### Specifications:

Post I.D.	Post Size	Post I.D.	Post Size
A	3-1/2" OD	F	2-3/8" OD
BL	3-1/2" OD	G	1-7/8" OD
BR	3-1/2" OD	T/U	1-5/8" OD
C	3-1/2" OD		

General: Our largest hooded backstop is furnished knocked-down with all parts and instructions necessary for assembly and installation. Basic backstop Model 1235-00 is furnished without rear-panel planking. Planking on rear panels is optional from 2-ft to 3-ft high.

Backup Channel: 1" X 2" X 3/16" X 22" Or 34" Steel Powder Coated Green

Hood Fittings: 4" O.D. x 2-7/8" O.D. galvanized steel are welded into an elbow for support posts & hood supports and secured to vertical posts with 1/4" x 1" drive screws. No threaded fittings are used.

 <p>ATHLETIC MFG. CO. Patterson-Williams QUALITY ATHLETIC AND PARK EQUIPMENT SINCE 1919</p>	Date: 09-21-09	<b>SPECIFICATION/INSTALLATION INSTRUCTIONS</b>  PERMANENT HOODED BACKSTOP
	Rev: A121912	
	Drawn: AMC	MODEL NO.
	Sheet: 1 of 6	<b>1235-00</b>

Chain Link Fabric: 2" mesh galvanized after weaving: 9 gauge on rear and side panels, 11 gauge on hood. Fabric is furnished in rolls ready for easy field attachment.

Hardware: Tension bars and bands are galvanized steel. All fasteners are included.

Finish: All welds are ground smooth. All fasteners are zinc plated for long rust-free service.

Dimension:

Front Opening	19-1/2" high x 54' wide	Side panels	12' high x 10' wide
Rear Panel	12' high x 40' wide	Front-to-Back	7-1/2' depth

Warranty: 3 years

**EXTREMELY IMPORTANT: DIG FOOTING HOLES ACCORDING TO LAYOUT & ASSEMBLE POST AND RAILS WITH SUPPLIED PIPE FITTINGS. DO NOT POUR CONCRETE UNTIL ENTIRE FRAME IS ASSEMBLED & ALIGNED.**

GENERAL NOTES: Site must be level. Seven 8" x 8" x 8" concrete blocks (half blocks) will be required in the bottom of holes to provide a means of post height adjustment as well as to provide sufficient concrete footing below bottom of posts (See Typical Footing Detail Page 6).

1. Determine location of backstop so the rear panel is perpendicular to a line running from 2nd base through home plate and so the wings are parallel with the sides of the diamond.
2. Dig holes according to footing plot plan (Page 1) and footing detail (Page 6).
3. Center a half concrete block (8" x 8" x 8") in the bottom of each of the holes per footing detail. Adjust height so the top of the block is 36" below finished grade (See Typical Footing Detail Page 6).
4. Start with an end post (Item A center the post in the hole so it rests on the block. Tops of posts for Model 1235 to be 12' above finish grade. Adjust block height as necessary to achieve proper post height. Plumb and brace in position. (See Footing Detail Page 6)
5. Repeat the same procedure for the adjacent right or left hand corner post (Item A, BL Or BR). If ordering rear planking adjust the angle mount bracket per exploded-view drawing (Page 1).

 <p><b>Patterson-Williams</b> ATHLETIC MFG. CO. QUALITY ATHLETIC AND PARK EQUIPMENT SINCE 1919</p>	Date:	09-21-09	<b>SPECIFICATION/INSTALLATION INSTRUCTIONS</b>  PERMANENT HOODED BACKSTOP
	Rev:	A121912	
	Drawn:	AMC	MODEL NO.
	Sheet:	2 of 6	1235-00

6. Attach two horizontal rails (Item T) between the two posts; one at the finished grade level and one midway up the posts. Attach with adapter 12AD-C1 & 12AD-C3 (See Attachment Detail Page 6).
7. Re-plumb posts and brace as necessary.
8. Set the adjacent center post (Item A Or C) in the hole on the concrete block. Align the angle mount brackets per plank detail. (See Page 1)
9. Attach one horizontal rail (Item T) between the center post (Item A Or C) and the corner post (Item A Or BL, BR). Install as before; one at finished grade level and one midway up the post with adapters provided.
10. Re-plumb posts and brace as necessary.
11. Repeat the same procedure for each adjacent post until all the seven vertical posts are installed. Attach horizontal rails between posts as before. Make sure the posts are plumb.
12. Slip the elbows for the upright posts (Item D) over the tops of the posts until seated. Using set screws, loosely tighten fitting in place.
13. Insert the center hood support w/"T" fitting (Item E) into the elbow on the center post (as shown on exploded view drawing on page 1) so the "T" fitting, is on top. Rotate so the "T" fitting will accommodate the right and left top horizontal rails.
14. Insert the six hood supports (Item F) into the elbows.
15. Align the hood supports by rotating the elbows, the hood supports on the corner and center posts (Items A, BL BR & C) should be rotated to face toward the infield and to be parallel to each other. The hood supports on the end posts (Item A) should be rotated so they are facing each other.
16. Install either the right or left top horizontal rail (Items G or H) so the straight end fits into the "T" fitting (on top of the center hood support). Insert the other fittings on the rail into the open ends of the hood supports. Rotate hood supports as necessary to align with fittings on rail.
17. Install the other top horizontal rail in the same manner.
18. Make sure the right and left top horizontal rails fit properly into the "T" fitting and the hood supports.

 <p><b>Patterson-Williams</b> ATHLETIC MFG. CO. QUALITY ATHLETIC AND PARK EQUIPMENT SINCE 1919</p>	Date:	09-21-09	<b>SPECIFICATION/INSTALLATION INSTRUCTIONS</b>
	Rev:	A121912	
	Drawn:	AMC	MODEL NO.
	Sheet:	3 of 6	<b>1235-00</b>

19. Install the other top horizontal rail in the same manner.
20. Make sure the right and left top horizontal rails fit properly into the "T" fitting and the hood supports.
21. Attach the shorter horizontal rails (Item U) at top of the vertical posts between the elbow fittings with the brace bands and carriage bolts provided.
22. Install the remaining horizontal rails (Item U) midway between the hood supports with brace bands and carriage bolts. Tighten all bolts, which secure all the horizontal rails.
23. Plumb frame. At all mating locations (elbows and top rail) drill with 7/32" drill bits provided, through both walls of pipe. Hammer 1/4" x 1" drive screws into holes until fully seated. Drill at least 2 holes at all mating locations.
24. Pour concrete in footings up to 2" of finished grade. Allow to set for 3 days.

Note: Continue below if backstop planks were ordered:

25. Install the rear panel planking. Note: all planks are the same and must be drilled in the field. Start with the bottom pieces in the center between the center posts (Item A Or C). Center the 2" x 12" planks so they 1" above finished grade allowing 1/4" between the planks. Drill 5/16" diameter holes through the planks using the holes in the angle mount brackets for hole location. Drill four holes per plank and secure with 5/16" x 2-1/2" carriage bolts, washer and nuts provided. Note: Tighten slowly so the shoulder of the carriage bolt will not strip out.
26. Repeat for both the far right and left hand bottom planks. Repeat drilling and mounting procedure as before.
27. Attach all the other planks in the same manner starting in the center and working outward, then upward. Allow 1/4" between edges of planks and 1/8" between ends of planks. Tighten hardware. Cut and peen any excess threads.

Note: Footing sizes are based on average soil conditions. Loose and/or sandy soil is not average and footing sizes must be increased accordingly to meet local soil conditions



12AD-A1



12AD-A2



12AD-C1

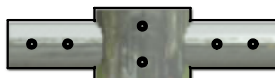

12AD-C2



12AD-C3



12EL-C1

	Date: 09-21-09	<b>SPECIFICATION/INSTALLATION INSTRUCTIONS</b>	
	Rev: A121912		PERMANENT HOODED BACKSTOP
	Drawn: AMC	MODEL NO.	<b>1235-00</b>
	Sheet: 4 of 6		

**Mesh Installation:**

1. Separate the wire mesh as the heavier material (9 gauge) is to be used along the rear panel and the wings while the lighter material (11 gauge) is to be used on the hood. The mesh is shipped in rolls.
2. Model 1235-02 & -03 - field cut six pieces (2 x 9ga x 12ft) mesh, 10ft long.
3. Secure the mesh to the top, center and bottom horizontal rails of the vertical posts with tie wires every 12 inches (see attachment detail.)
4. The mesh will overlap the top planks. Install the drilled tension bar in the mesh about 3" to 6" from the top edge of the highest plank. Pull tight and drill 5/16" diameter holes through the planks using the holes in the tension bar for hole location. Secure with 5/16" x 2-1/2" carriage bolts, washer and nuts.
5. Cut the lighter weight mesh (11 gauge) for the hood in two pieces 10ft x 20ft.
6. Attach the 10ft x 20ft pieces on the hood above the rear panel. Use one tension bar on each end of each piece along with tension bands and hardware provided. Tension bands should be used on 18 to 20 inch centers. The mesh must be tight, remove strands as necessary to achieve proper tension.
7. Secure the mesh to the top, center and bottom horizontal rails of the hood supports with tie wires every 12 inches (See Attachment Detail Page 6).
8. Cut two (2) triangles out of the remaining 11 ga. mesh. Note: Lay excess mesh on triangle sections and cut accordingly.
9. Install two 10ft. tension bars in each triangular mesh piece along the two edges where the wire ends are NOT twisted together (knuckled salvage edge). Attach the mesh in the corners of the hood so the edge of mesh without tension bar is along the horizontal rail. Use tension bands on 18 to 20 inch centers to secure to the hood supports (Item F). The mesh must be tight; remove one or two strands as necessary to achieve proper tension.
10. Pull the bottom of each triangular mesh piece tight and secure with tie wires every 8 inches to the horizontal rails.
11. Inspect for loose hardware and tighten as necessary. Also look for sharp wires and either cut or turn back into the fabric as necessary. Make sure all setscrews are tight. 10. At every mating location (Elbows & Top Rail) drill through with 7/32" drill bit and hammer 1/4" x 1" drive screws into holes until seated.
12. Install backup channels on models 1235-02 and 1235-03 using 5/16" X 3-1/2" carriage bolts, flat washers, split washers and nuts. (See Backup Channel Detail)
13. Replace turf to cover exposed tops of footings (see typical footing detail).

**EXTREMELY IMPORTANT:**

**DIG FOOTING HOLES ACCORDING TO LAYOUT & ASSEMBLE POST AND RAILS WITH SUPPLIED PIPE FITTINGS. DO NOT POUR CONCRETE UNTIL ENTIRE FRAME IS ASSEMBLED & ALIGNED.**

 <p><b>Patterson-Williams</b> ATHLETIC MFG. CO. QUALITY ATHLETIC AND PARK EQUIPMENT SINCE 1919</p>	Date:	09-21-09	<b>SPECIFICATION/INSTALLATION INSTRUCTIONS</b>
	Rev:	A121912	
	Drawn:	AMC	MODEL NO.
	Sheet:	5 of 6	<b>1235-00</b>

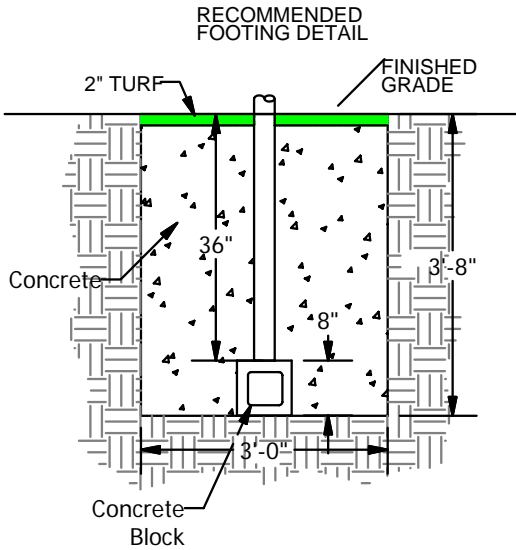

Component Description	Qty
2-3/8" Tension Band	56
3-1/2" Tension Band	96
2-3/8" Brace Band	8
3-1/2" Brace Band	24
4" Brace Band	12
1-5/8" Rail End	12
#10 x 1/2" Tek Drive Screw	44
5/16"-18 x 1" Carriage Bolt	200
5/16"-18 Hex Nut	200
5/16" Lock Washers	200
1/4" x 1" Drive Screw	50
12 Gauge Tie Wire (lbs)	8
7/32" Drill Bit	3
#25 Drill Bit	2
5/8" x 7/8" Set Screws	35
3/8" x 3/8" Set Screws	110

Description	Qty
Vertical Post 3-1/2" (A B & C)	7
Top Hood Horizontal Rail Assy 1-7/8" (LT) (G)	1
Top Hood Horizontal Rail Assy 1-7/8" (RT) (H)	1
Center Hood Support w/ Splice 2-3/8" (E)	1
Hood Support 2-3/8" (F)	7
Horizontal Rails 1-5/8" (T) (9'-7")	16
Horizontal Rails 1-5/8" (U) (9'-4")	6
2" X 11 Gauge X 10' Wire Mesh (ft)	60
2" X 9 Gauge X 12' Wire Mesh (ft)	60
10' Tension Bar	8
12' Tension Bar	12
Hardware Kit	1
FITTING 12AD-A1 for 2-3/8" Post	2
FITTING 12AD-C1 for 3-1/2" Post	4
FITTING 12AD-A2 for 2-3/8" Post	3
FITTING 12AD-C2 for 3-1/2" Post	6
FITTING 12AD-C3 for 3-1/2" Post	4
FITTING 12EL-C1 for 3-1/2" to 2-3/8" Elbows	7

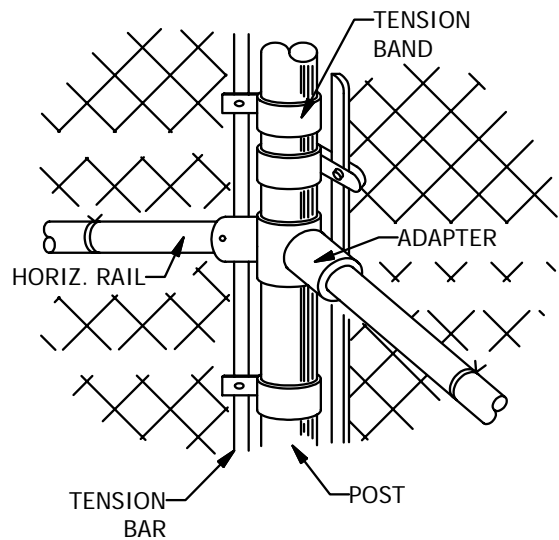

 <p><b>Patterson-Williams</b> ATHLETIC MFG. CO. QUALITY ATHLETIC AND PARK EQUIPMENT SINCE 1919</p>	Date: 09-21-09	<b>SPECIFICATION/INSTALLATION INSTRUCTIONS</b>	
	Rev: A022713		PERMANENT HOODED BACKSTOP
	Drawn: AMC	MODEL NO.	<b>1235-00</b>
	Sheet: 6 of 6		