

SINGLE BASKETBALL POST

MODEL #1523 4-1/2" O.D. WITH 4' OFFSET (185 LBS)

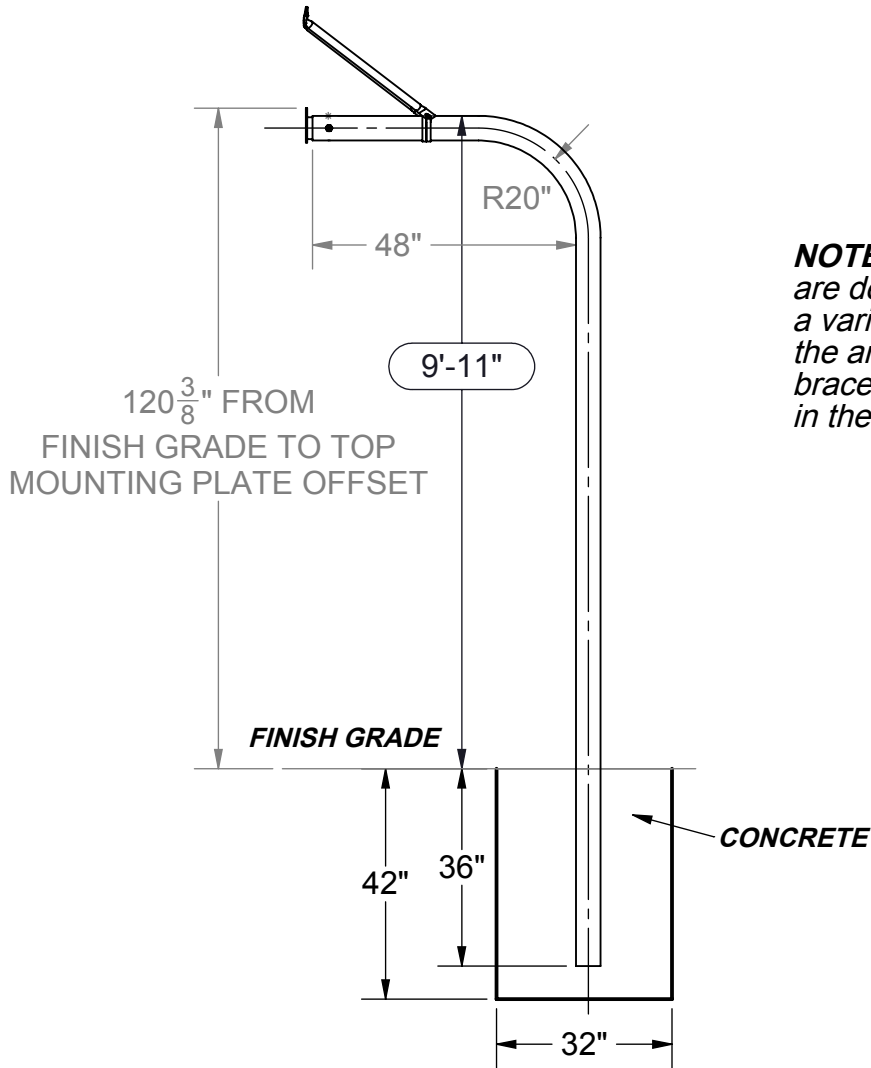
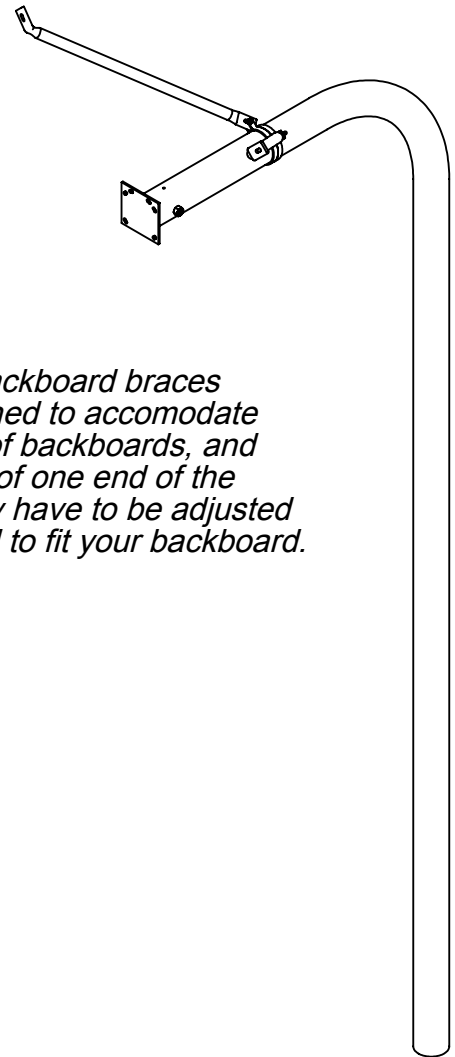

NOTE: Backboard braces are designed to accommodate a variety of backboards, and the angle of one end of the brace may have to be adjusted in the field to fit your backboard.

SPECIFICATIONS:

Material: Support post is a single length of 4-1/2" O.D. galvanized steel formed to provide a graceful 4 ft offset. Backboard mount is a 6-1/4" x 6-1/2" steel plate welded to the sleeve adapter then mounted to support post with set screw & drive pin.

A pair of diagonal braces, 1-3/8" O.D. galvanized steel, is mounted between the backboard and the post. Braces bolt to the backboard and are secured to the post with a pair of steel clamps formed to fit the post diameter.

All welds are either treated with cold-galvanizing compound or prepared for powder coating, depending on finish selected. All hardware is zinc-plated for long rust-free service.



Date: 3/19/2007

Rev: SS81817

Drawn: MT

Sheet: 1 of 2

SPECIFICATION / INSTALLATION INSTRUCTIONS

SINGLE POST GOOSENECK

MODEL NO.

1523

PERMANENT FOOTING DETAIL

NOTE: Footing sizes are based on average soil conditions. Loose and/or sandy soil is not average and footing sizes must be increased accordingly to meet soil conditions and local building codes and specifications. Post depth is approximate, and should be adjusted to ensure that the top of the Gooseneck offset post is 9'-11" above finish grade.

INSTALLATION INSTRUCTIONS:

1. Dig a hole in desired location per footing chart dimensions. Set the bottom of the post in center of the hole and shim from below or fill such that the top of the Gooseneck Post on the offset is (9' 11") above finish grade. Plumb post true vertical and brace. NOTE: Top of rim will be at 10' when installed.

NOTE: Verify that the backboard mounting plate is perpendicular to the surface by using a level (vertical) before pouring concrete.

2. Pour concrete and allow the concrete to set for 3 days before removal of bracing and completion of installation. Cover footings with turf or court materials.
3. Attach diagonal braces with the brace bands and carriage bolts provided. Slip both brace bands onto post and attach with carriage bolts.
4. *Refer to backboard installation instructions to complete backboard & GNP Adapter installation.*
5. Slide brace bands and braces toward the back of the backboard until the opposite end of the diagonal brace aligns with attachment angles or nuts. NOTE: Attach the diagonal braces either to welded nuts or attachment angles, depending on backboard.
6. Tighten all bolts.
7. Once everything is tightened drill 1/4" Drive Pin holes in the GNP Adapter through the Gooseneck holes on top & bottom of offset end with the undersized (7/32" Drill Bit).

Packing Slip	Qty
4-1/2" O.D. Gooseneck Post 4' Offset	1
4" GNP Adapter	1
35" Diag. Brace	1
36" Diag. Brace	1
4-1/2" O.D. Brace Band	2
Hardware Kit	Qty
5/16"-18 x 1-1/4" Carriage Bolt	2
5/16"-18 Nylock Nut	2
5/8" Set Screw	1
1/4" SS Drive Pin	2
5/16" Hex Key Wrench	1

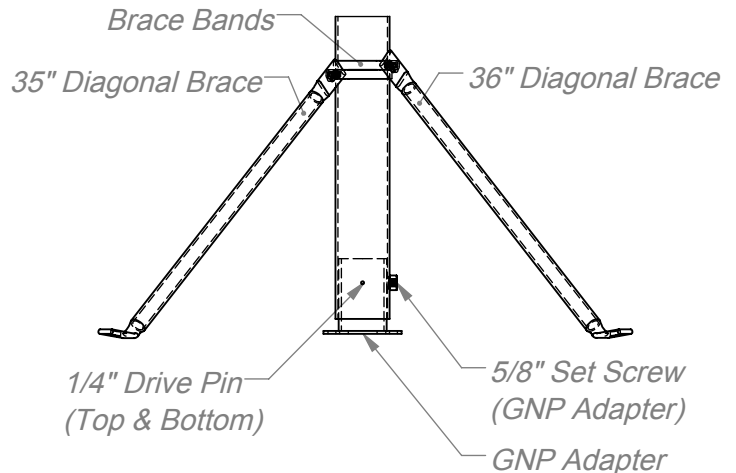

Date: 4/9/16
 Rev: SS81817
 Drawn: MT
 Sheet: 2 of 2

SPECIFICATION / INSTALLATION INSTRUCTIONS

SINGLE POST GOOSENECK

MODEL NO.

1523

Pick Ticket

Internal use only return to office with packet

Fabrication to Provide Gooseneck. GNP Adaptor and Braces Should be in Stock to be pulled from shipping
If shortage occurs Please notify office personnel immediately. Brace bands and hardware to be pulled by shipping.

Packing Slip	Qty
4-1/2" O.D. Gooseneck Post 4' Offset	1
4" GNP Adapter	1
35" Diag. Brace	1
36" Diag. Brace	1
4-1/2" O.D. Brace Band	2
Hardware Kit	Qty
5/16"-18 x 1-1/4" Carriage Bolt	2
5/16"-18 Nylock Nut	2
5/8" Set Screw	1
1/4" SS Drive Pin	2
5/16" Hex Key Wrench	1

