

# SINGLE POST W/ADJUSTABLE OFFSET

**MODEL #1537 - 5-9/16" O.D. W/5' OFFSET (310lbs)**

## **SPECIFICATIONS:**

**A heavy-duty 5-9/16" O.D. galvanized steel upright post with top end capped, and that supports an adjustable 5ft. offset.**

**Adjustable offset assembly is of welded construction consisting of 2 pieces of 2-3/8" O.D. galvanized steel (one horizontally and one diagonally), welded to a 1/4"x6-1/4"x6-1/2" steel backboard mount plate at one end and a pair of steel half clamps at the opposite end.**

**Heavy-duty 1/4" thick half clamps, formed to fit the diameter of the post, secure to the support post with (8) 1/2" diameter bolts.**

**A pair of braces made of 1-3/8" O.D. galvanized steel are mounted between the backboard and the adjustable offset.**

**All hardware is zinc-plated for long rust free service.**

**Warranty Period: Limited Lifetime**

**Post depth's are approximate, and should be adjusted to insure that the top of the mounting plate is 10' 0-3/8" above the finish grade.**

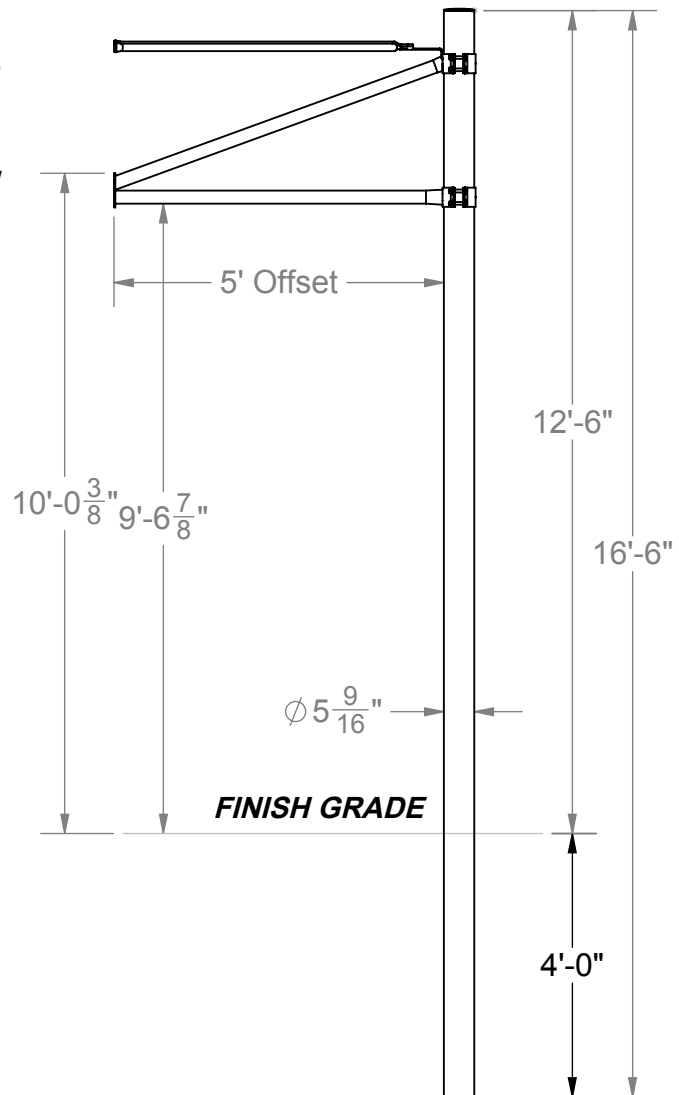
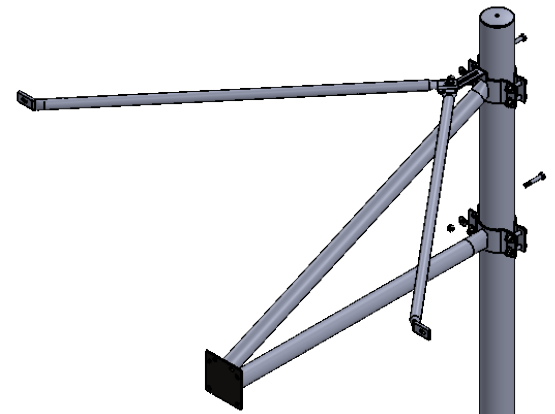

## **TYPICAL FOOTING DETAIL**

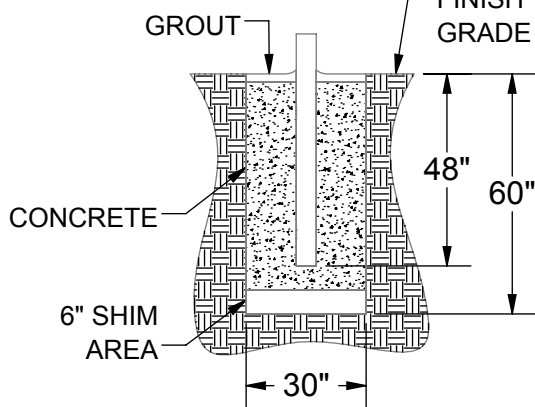

Date: 1/21/2015  
 Rev: 10/27/16  
 Drawn: MT  
 Sheet: 1 of 2

## **SPECIFICATION/INSTALLATION INSTRUCTIONS**

*SINGLE POST W/ ADJUSTABLE OFFSET*

MODEL NO.

**1537**

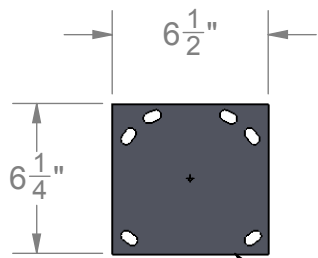

Bottom of Universal Mounting Plate

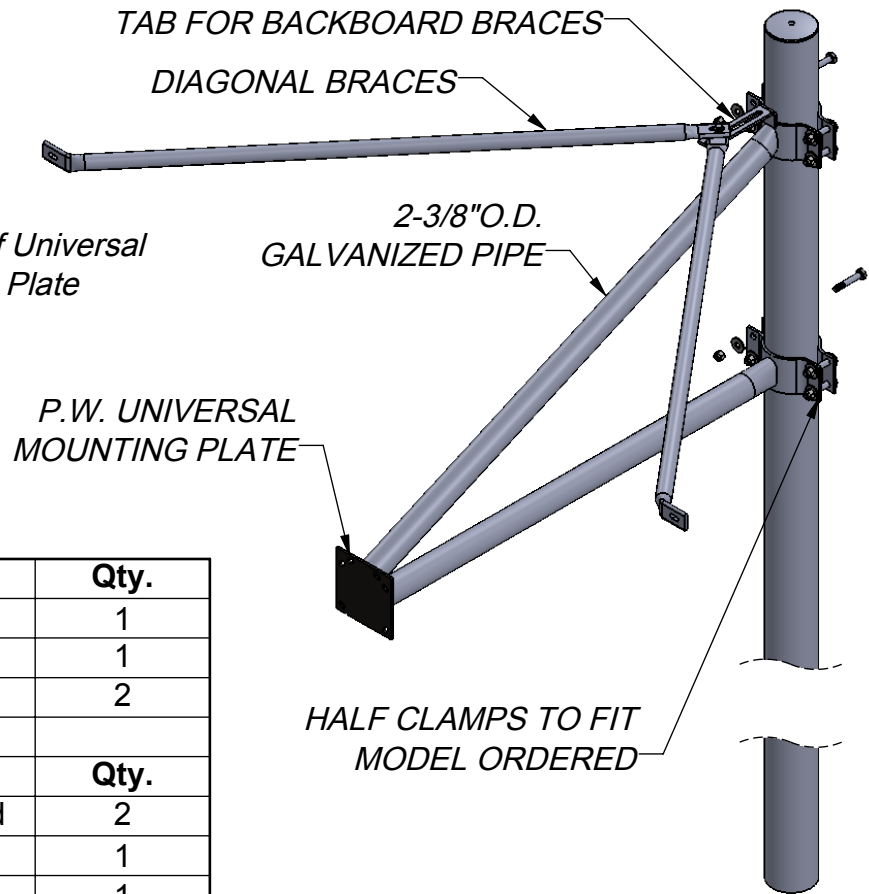

HALF CLAMPS TO FIT MODEL ORDERED

Packing Slip	Qty.
5-9/16" O.D. Post	1
5' Adjustable Offset Assembly	1
Diagonal Braces	2
Hardware Kit	Qty.
5-9/16" Half Clamp - Galvanized	2
3/8"-16 x 2" Hex Bolt	1
3/8"-16 Lock Nut	1
3/8" Flat Washer	2
1/2"-13 x 3" Hex Bolt	8
1/2"-13 Lock Nut	8
1/2" Flat Washer	16

**INSTALLATION INSTRUCTIONS:**

1. Dig a hole in desired location per footing chart dimensions (see sheet 1). Set the bottom of the support post in the hole & shim from below & brace so THE CAP IS ON TOP & the top of the post is 12'-6" above finish grade. Plumb post true vertical & brace. Pour concrete to 2" below finish grade. Allow concrete to set for 3 days before removal of bracing & completion of installation. Cover footing w/ turf or court materials.
2. Adjustable offset assemblies are equipped w/ half clamps formed to fit the diameter of the post. Single offsets are equipped w/ back-up half clamps. Set clamps back-to-back over the post at ground level. Use 1/2" x 3" hex bolts, washers & lock nuts to attach (8total are provided). Tighten hardware slightly.
3. Slide the offset assembly up the post until the top of the backboard mounting plate 3/8" above the goal ring height desired. Align offsets w/ court(s). Tighten clamp bolts securely. Note: Official goal ring height is 10ft, but height is adjustable to accommodate various age groups & physically challenged children & adults.
4. Attach 4' braces to offset assemblies. Attach both the straight (non-formed) ends to the mounting tabs.
5. Attach to backboard. Use backboard install for installation instructions.

	Date: 1/21/2015	<b>SPECIFICATION/INSTALLATION INSTRUCTIONS</b>
	Rev: 10/27/16	
	Drawn: MT	MODEL NO.
	Sheet: 2 of 2	<b>1537</b>