

BACK TO BACK GOOSENECK POSTS

MODEL #1561 6-5/8" O.D. WITH 6' OFFSET (752 LBS)

Verify the vertical position of the mounting plates using a level.

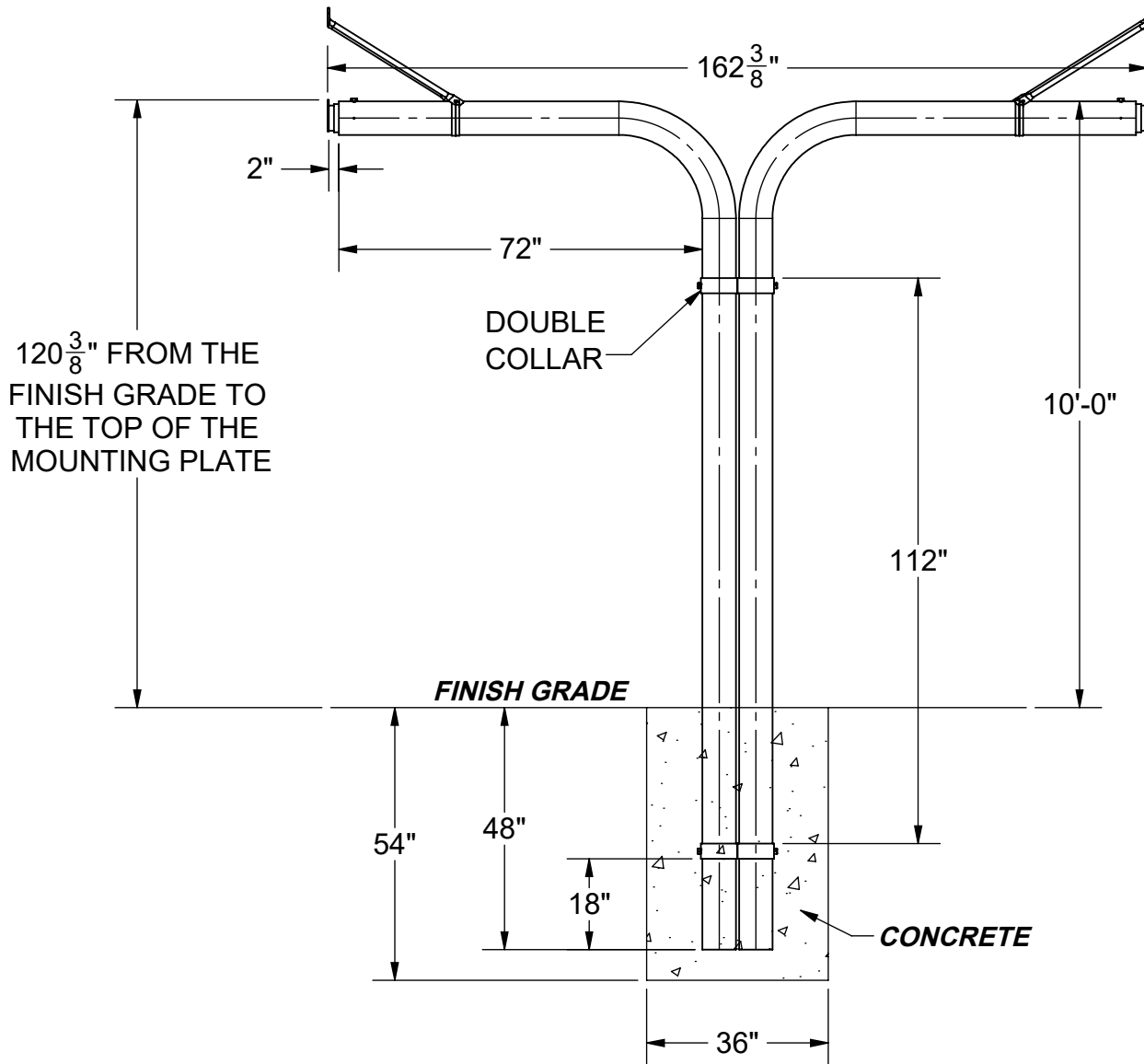

SPECIFICATIONS:

Material: Each support post is a single length of 6-5/8" O.D. galvanized steel formed to provide a graceful 6 ft. offset. The backboard mount is a 6-1/4" x 6-1/2" steel plate welded to each sleeve adapter and mounted to the support post with a set screw and drive pins.

A pair of 1" O.D. galvanized steel diagonal braces is mounted between the backboard and the post. The braces bolt to the backboard and are secured to the post with a pair of brace bands formed to fit the post diameter.

All the welds are ground smooth and either treated with cold-galvanizing compound or prepared for powder coating, depending on finish selected. All the hardware is zinc-plated for long rust-free service.



Date: 2/23/16
 Rev: 8/17/23
 Drawn: MT
 Sheet: 1 of 2

SPECIFICATION / INSTALLATION INSTRUCTIONS

BACK TO BACK GOOSENECK POSTS

MODEL NO.

1561-SPEC

PERMANENT FOOTING DETAIL

NOTE: Footing sizes are based on average soil conditions. Loose and/or sandy soil is not average and footing sizes must be increased accordingly to meet soil conditions and local building codes and specifications. The post depth is approximate and should be adjusted to ensure that the top of the mounting plate is 10' 0-3/8" above the finish grade.

INSTALLATION INSTRUCTIONS:

1. Dig a hole in desired location per footing chart dimensions. Set the bottom of the post in the center of the hole and shim from below or fill such that the top of the Gooseneck Post on the offset is **10'** above finish grade. Plumb the post to true vertical and brace.
NOTE: The top of the rim will be at 10' when installed.
- NOTE:** Verify that the backboard mounting plate is perpendicular to the surface by using a vertical level before pouring the concrete.
2. Pour the concrete and allow it to set for 3 days before the removal of the bracing and completion of the installation. Cover the footings with turf or court materials.
3. Slide the brace bands onto the posts and attach the diagonal braces to them with the carriage bolts and lock nuts provided.
4. Refer to the backboard installation instructions to complete the backboard & GNP Adapter installation.
5. Slide the brace bands and diagonal braces toward the back of the backboard until the opposite end of the diagonal brace aligns with the attachment angles or nuts. **NOTE:** Attach the diagonal braces either to the welded nuts or attachment angles, depending on the backboard.
6. Tighten all the bolts.
7. Once everything is tightened, drill the Drive Pin holes in the GNP Adapter through the Gooseneck holes on the left and right side of the offset end with a 7/32" drill bit.
8. Install the two drive pins to complete the installation.

Packing Slip	Qty
6-5/8" O.D. 6' Offset Gooseneck Post	2
6" GNP Adapter	2
6-5/8" Double Basketball Collar	2
35" Diagonal Brace	2
36" Diagonal Brace	2
6-5/8" Brace Bands	4
Hardware Kit	
3/8"-16 x 1-1/4" Carriage Bolt	4
3/8" Nylock Nut	4
5/8"-11 x 1" Socket Head Set Screw	6
1/4" SS Drive Pin	4

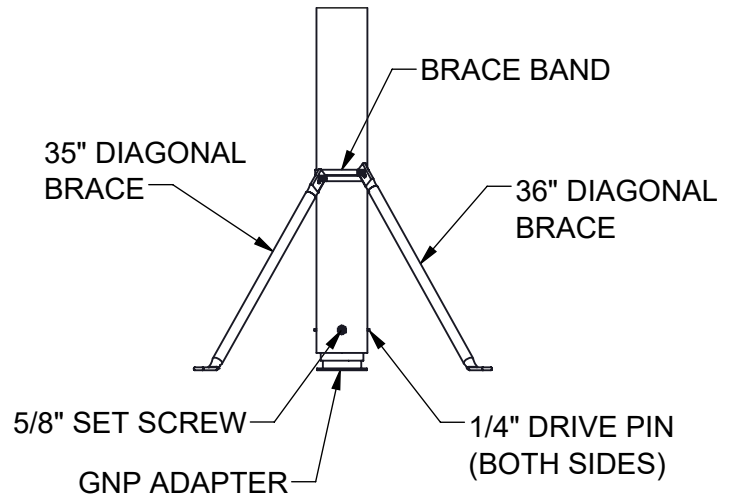

TOP VIEW



Date: 2/23/16
 Rev: 8/17/23
 Drawn: MT
 Sheet: 2 of 2

SPECIFICATION / INSTALLATION INSTRUCTIONS

BACK TO BACK GOOSENECK POSTS

MODEL NO.

1561-SPEC