

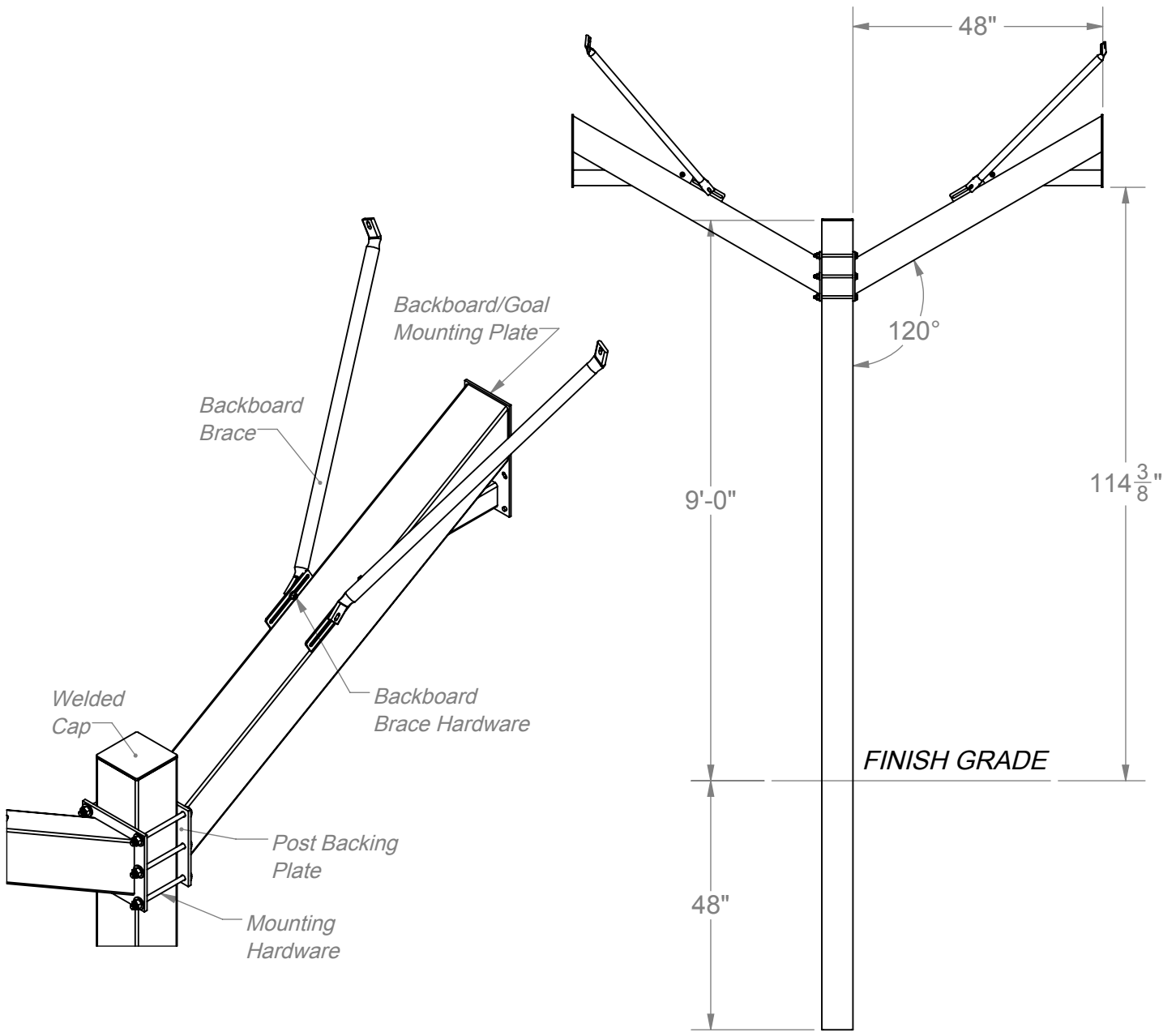

6" SQUARE POST/ ADJUSTABLE

MODEL #1578 6" SQUARE POST BACK TO BACK W/ 4' OFFSET (425 LBS)



SPECIFICATIONS:

Upright Post is 6" x 6" x 1/4" square, heavy-duty steel, capped on top. The 6" x 6" square offset is a 1 piece welded construction with a 1/4" x 6-1/2" x 14" steel backboard goal mounting plate & a 3/8" x 8-1/2" x 9-1/2" post backing plate. Available with 4 ft. & 5 ft. offsets. Height adjustment of the goal permits regulation play (10 ft goal ring height) or lowering offsets for use by preschool, elementary school age, physically challenge children or adults. Backboard braces are 1-3/8" O.D. galvanized steel. All hardware is zinc-plated (rust free).

 <p>ATHLETIC MFG. CO.</p>	Date: 2/24/16	SPECIFICATION / INSTALLATION INSTRUCTIONS
	Rev: 8/22/16	
	Drawn: MT	MODEL NO.
	Sheet: 1 of 2	1578

NOTE: Footing sizes are based on average soil conditions. Loose and/or sandy soil is not average and footing sizes must be increased accordingly to meet soil conditions and local building codes and specifications. Post depth is approximate, and should be adjusted to ensure that the top of the mounting plate is 10' 0-3/8" above finish grade.

INSTALLATION INSTRUCTIONS:

1. Dig/prepare hole in desired location per footing chart dimensions. Set the bottom of the post in center of the hole & shim from below or fill such that the top of the post (CAPPED END) is 9' above finish grade. Plumb post to true vertical & brace.
2. Pour concrete & allow the concrete to set for 3 days before removal of bracing & completion of installation. Cover footings with turf or court materials.
3. Place offset on support post using supplied bolts & steel post backing plate. Loosely place nuts on the bolts of backing plate. Raise offset to desired height (Approx. 8" above desired height, see side view page 2), always maintaining blocks under offset to prevent offset from slipping down on post. After offset is in approximate position (Approx. 8" above desired height), install backboard & rim per instructions of models chosen. Measure to proper height, & tighten bolts on backing plate.
4. Attach braces to offset mounting bracket & points on backboard.

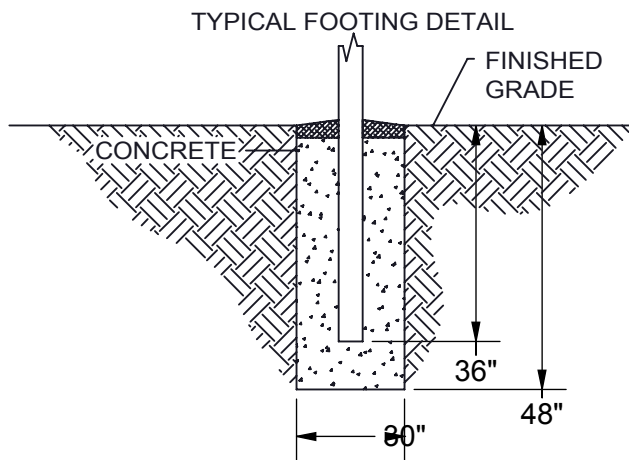

Packing Slip		Qty
6" Square x 13' Upright Post		1
6" Square x 4' Offset Post		2
Diagonal Brace (Left)		2
Diagonal Brace (Right)		2
Hardware Kit		Qty
1/2" x 8" Hex Bolt		6
1/2" Flat Washer		12
1/2" Nylock Nut		6
3/8" x 2" Hex Bolt		4
3/8" Flat Washer		8
3/8" Nylock Nut		4



Date: 2/24/16
 Rev: 8/22/16
 Drawn: MT
 Sheet: 2 of 2

SPECIFICATION / INSTALLATION INSTRUCTIONS

6" SQ. POST BASKETBALL SYSTEM

MODEL NO.

1578