

# TRUSS POST GOOSENECK

**MODEL #1584** 4-1/2" O.D. WITH 5' OFFSET (W/ GUSSET) (219 LBS)

**Verify vertical position of mounting plate using level.**

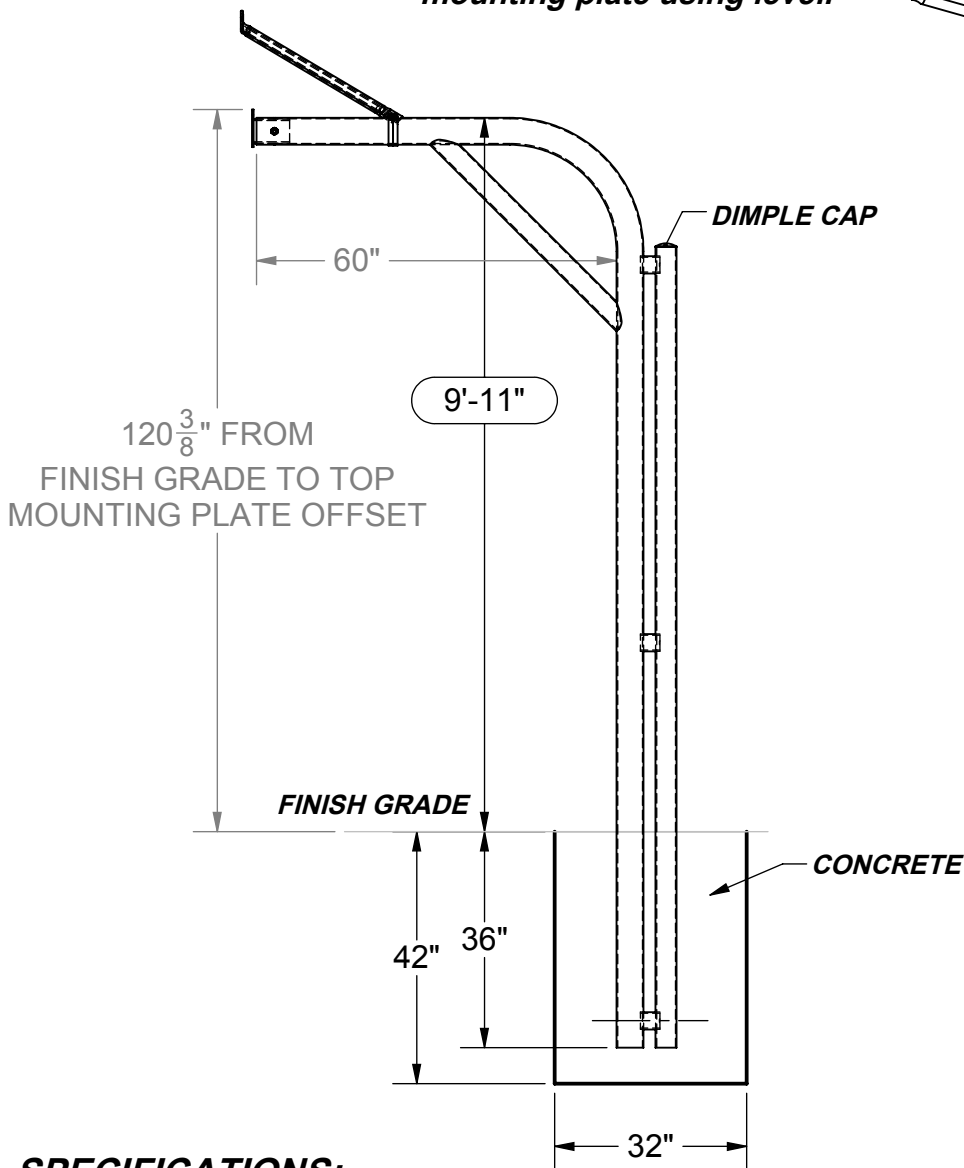

## SPECIFICATIONS:

**Material:** Support post is a single length of 4-1/2" O.D. galvanized steel formed to provide a graceful 5 ft offset. Provided as an extra vertical stabilizer, the Truss Post Brace running parallel of gooseneck post is a 3-1/2" O.D. galvanized steel tube connected by welding two stubs perpendicular. Backboard mount is a 6-1/4" x 6-1/2" schedule 40 steel plate welded to the GNP sleeve adapter then mounted to support post with set screw & drive pins.

A pair of diagonal braces, 1-3/8" O.D. galvanized steel, is mounted between the backboard and the post. Braces bolt to the backboard and are secured to the post with a pair of steel clamps formed to fit the post diameter.

All welds are ground smooth and either treated with cold-galvanizing compound or prepared for powder coating, depending on finish selected. All hardware is zinc-plated for long rust-free service.



Date: 10/1/15  
 Rev: 11/30/16  
 Drawn: MT  
 Sheet: 1 of 2

## **SPECIFICATION / INSTALLATION INSTRUCTIONS**

*TRUSS POST W/ 5' OFFSET (W/GUSSET)*

MODEL NO.

**1584**

# PERMANENT FOOTING DETAIL

**NOTE:** Footing sizes are based on average soil conditions. Loose and/or sandy soil is not average and footing sizes must be increased accordingly to meet soil conditions and local building codes and specifications. Post depth is approximate, and should be adjusted to ensure that the top of the Gooseneck offset post is 9' 11" above finish grade.

## **INSTALLATION INSTRUCTIONS:**

1. Dig a hole in desired location per footing chart dimensions. Set the bottom of the post in center of the hole and shim from below or fill such that the top of the Gooseneck Post on the offset is (9' 11") above finish grade. Plumb post true vertical and brace. NOTE: Top of rim will be at 10' when installed.

**NOTE:** Verify that the backboard mounting plate is perpendicular to the surface by using a level (vertical) before pouring concrete.

2. Pour concrete and allow the concrete to set for 3 days before removal of bracing and completion of installation. Cover footings with turf or court materials.
3. Attach diagonal braces with the brace bands and carriage bolts provided. Slip both brace bands onto post and attach with carriage bolts.
4. \*Refer to backboard installation instructions to complete backboard & GNP Adapter installation.\*
5. Slide brace bands and braces toward the back of the backboard until the opposite end of the diagonal brace aligns with attachment angles or nuts. NOTE: Attach the diagonal braces either to welded nuts or attachment angles, depending on backboard.
6. Tighten all bolts.
7. Once everything is tightened drill 1/4" Drive Pin holes in the GNP Adapter through the Gooseneck holes on top & bottom of offset end with the undersized (7/32" Drill Bit).

<b>Packing Slip</b>	<b>Qty</b>
4-1/2" O.D. Gooseneck Truss Post 5' Offset	1
4" GNP Adapter	1
35" Diag. Brace	1
36" Diag. Brace	1
4-1/2" O.D. Brace Band	2
<b>Hardware Kit</b>	<b>Qty</b>
5/16"-18 x 1-1/4" Carriage Bolt	2
5/16"-18 Nylock Nut	2
5/8"-11 x 3/4" Socket Hd. Set Screw	1
1/4" SS Drive Pin	2
5/16" Hex Key Wrench	1

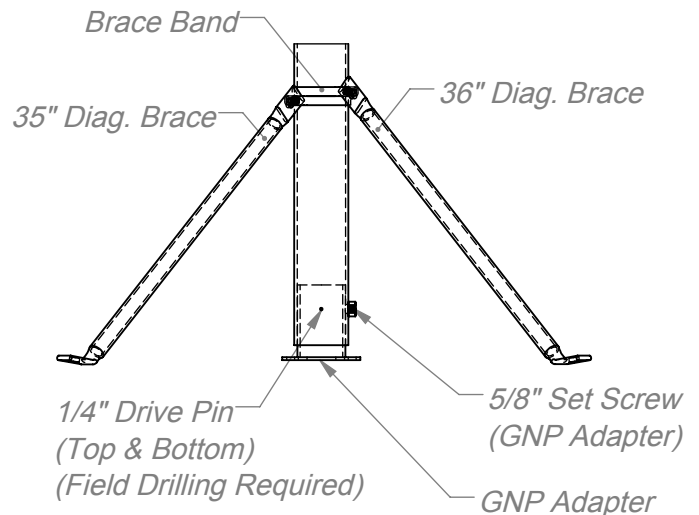

Date: 10/1/15  
 Rev: 11/30/16  
 Drawn: MT  
 Sheet: 2 of 2

## **SPECIFICATION / INSTALLATION INSTRUCTIONS**

*TRUSS POST W/ 5' OFFSET (W/GUSSET)*

MODEL NO.

**1584**