

SITE FURNISHINGS

- MODEL #1603-04 4 Bike Spaces, Single Sided (40lbs)
- MODEL #1603-08 8 Bike Spaces, Single Sided (80lbs)
- MODEL #1603-07 7 Bike Spaces, Doubled Sided (70lbs)
- MODEL #1603-15 15 Bike Spaces, Doubled Sided (122lbs)

SPECIFICATIONS:

A heavy-duty, steel rod bike rack for areas with space, or multi-use where space is limited.

MATERIAL: -Formed from 1/2" O.D. Solid Steel Rod
-2 x 2 Angle

FINISH: Galvanized or powder coated

WARRANTY PERIOD: 10 years

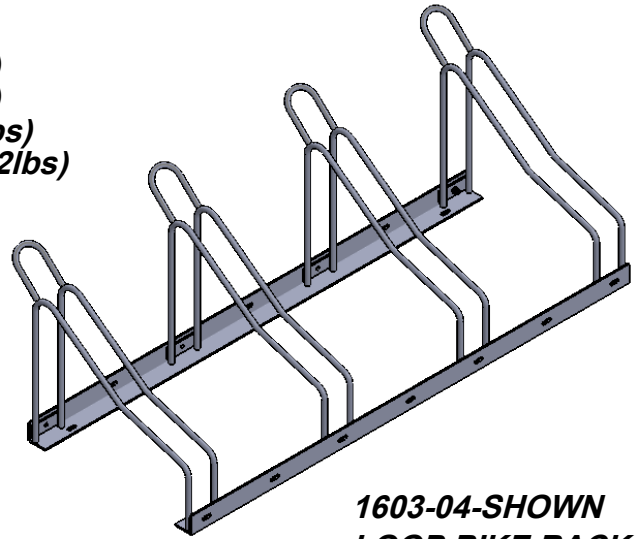

**1603-04-SHOWN
LOOP BIKE RACK**

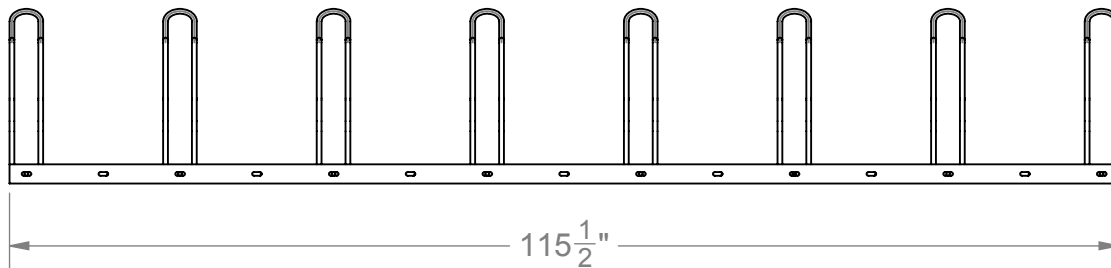
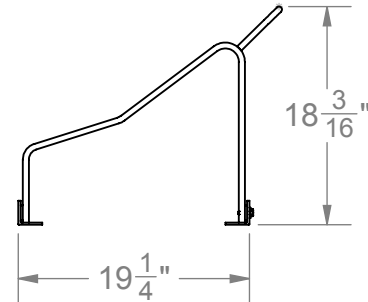
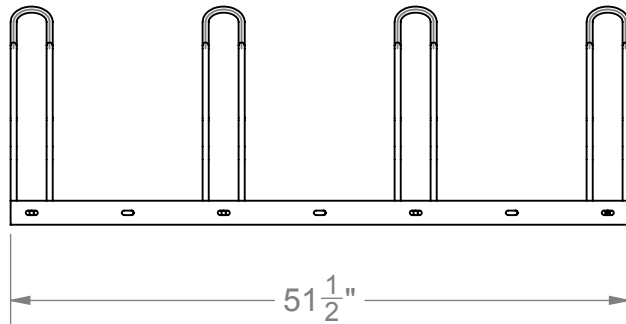

**1603-08
LOOP BIKE RACK**

PACKING SLIP		
DESCRIPTION	1603-04 QTY	1603-07 QTY
1603 LOOP - SA	4	7
2 X 2 ANGLE	2	2
5/16" x 1" Hex Bolt	8	14
5/16" Flat Washer	8	14
5/16" Split Washer	8	14
5/16" Nylock Nut	8	14

INSTALLATION INSTRUCTIONS:

Attach the Loops to the 2 x 2 Angle with required hardware. Then anchor to concrete or surface area.

NOTE: Bike rack must be anchored. Anchoring hardware not included.



SITE FURNISHINGS

SCALE: N.T.S.
DATE: 4/23/2013
DRAWN: MT
REV: 3/17/17
SHEET: 1 of 2

SPECIFICATION / INSTALLATION INSTRUCTIONS

LOOP BIKE RACK

1603

SITE FURNISHINGS

**1603-08
LOOP BIKE RACK**

**1603-15
LOOP BIKE RACK**

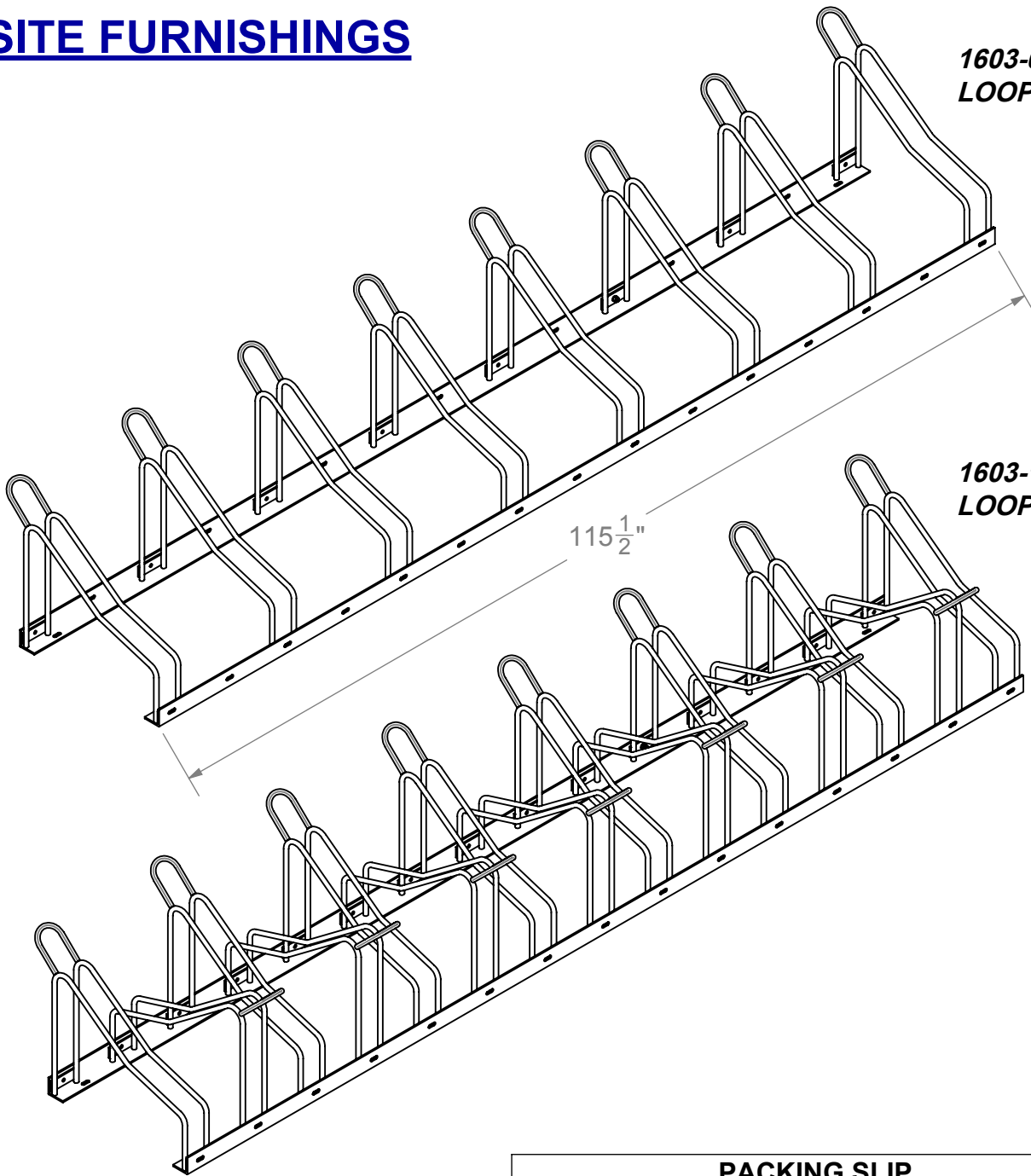

PACKING SLIP		
DESCRIPTION	MODEL 1603-08 QTY	MODEL 1603-15 QTY
1603 LOOP - SA	8	15
2 X 2 ANGLE	2	2
5/16" x 1" Hex Bolt	16	30
5/16" Flat Washer	16	30
5/16" Split Washer	16	30
5/16" Nylock Nut	16	30



SITE FURNISHINGS

SCALE: N.T.S.
DATE: 4/23/2013
DRAWN: MT
REV: 3/17/17
SHEET: 2 of 2

SPECIFICATION / INSTALLATION INSTRUCTIONS

LOOP BIKE RACK

1603