

8 7 6 5 4 3 2 1

D

C

B

A

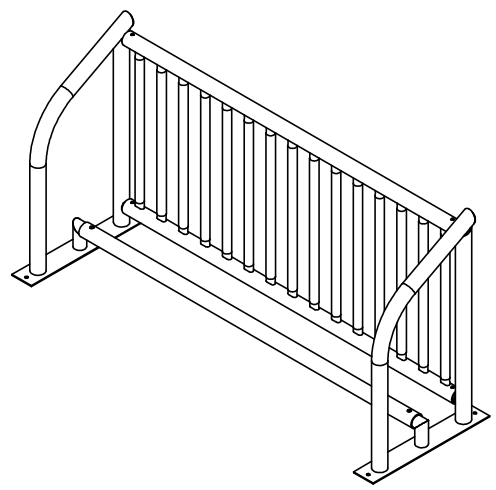
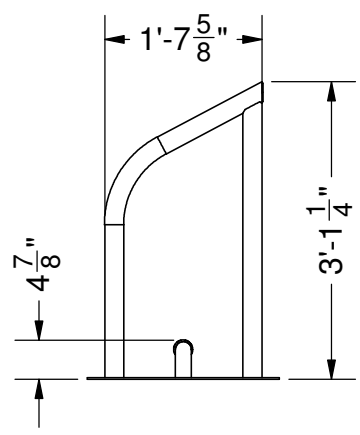
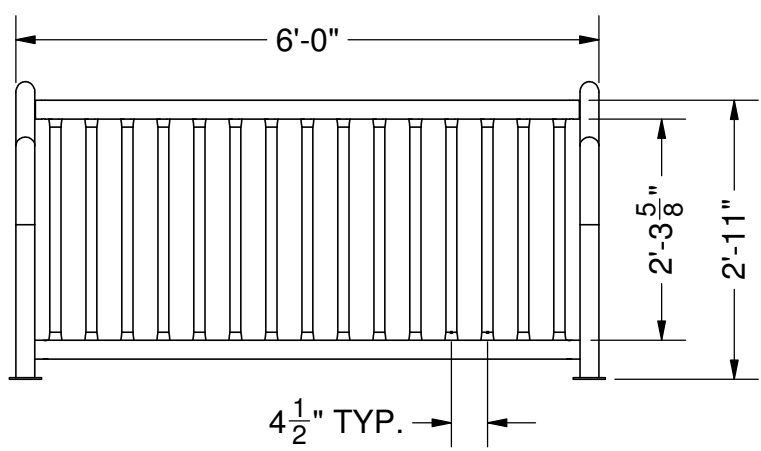
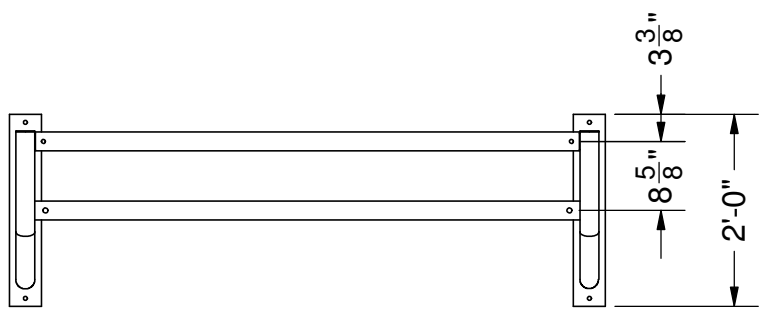

GENERAL NOTES:

1. STEEL
 - A. STEEL PLATE SHALL CONFORM TO THE REQUIREMENTS OF ASTM A36.
 - B. STEEL TUBING SHALL CONFORM TO THE REQUIREMENTS OF ASTM A500.
 - C. STEEL PIPE SHALL CONFORM TO THE REQUIREMENTS OF ASTM A53.
 - D. WELDING SHALL CONFORM TO THE REQUIREMENTS OF THE AMERICAN WELDING SOCIETY'S SPECIFICATION FOR THE MATERIAL BEING WELDED.
 - E. WELDING ELECTRODES SHALL BE E70XX.
2. FASTENERS
 - A. BUTTON HEAD SOCKET BOLTS SHALL CONFORM TO THE REQUIREMENTS OF ASTM F835.
 - B. BOLTS SHALL BE ZINC PLATED ACCORDING TO THE REQUIREMENTS OF ASTM B633.
3. FINISH
 - A. COMPONENTS SHALL BE COATED WITH POLYESTER TGIC POWDER COAT FINISH MEETING AAMA 2604-02 SPECIFICATION.

PATTERSON WILLIAMS MFG. CO.
 P.O. BOX 1290 - SALEM, IL 62881
 (800) 851-0865 - www.pwathletic.com

TITLE			
NEWPORT BIKE RACK			
SIZE	DATE	MODEL NO	REV
A	4/11/2013	1606-06	
SCALE:	1/2" = 1'-0"	DRAWN: AY	SHEET 1 of 1

8 7 6 5 4 3 2 1