

8 7 6 5 4 3 2 1

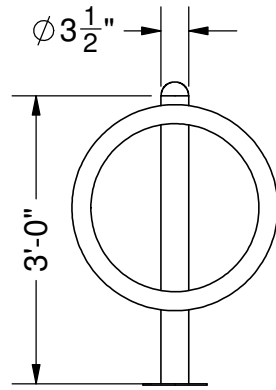

MODEL 1701

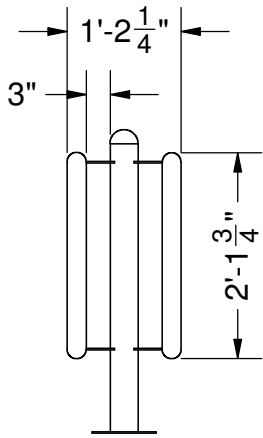
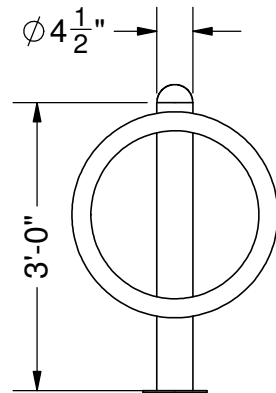
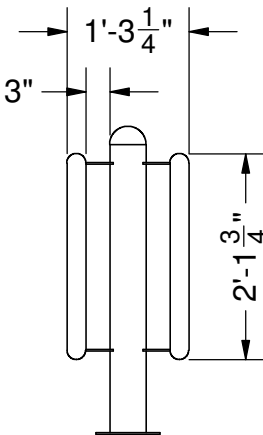

MODEL 1702

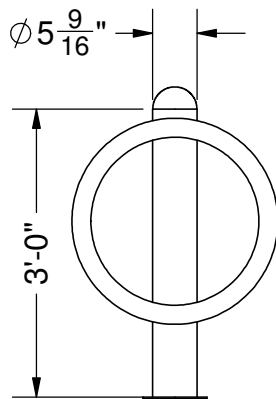
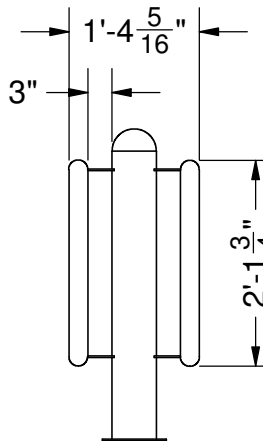

MODEL 1703

GENERAL NOTES:

1. STEEL
 - A. STEEL PLATE SHALL CONFORM TO THE REQUIREMENTS OF ASTM A36.
 - B. STEEL TUBING SHALL CONFORM TO THE REQUIREMENTS OF ASTM A500.
 - C. STEEL PIPE SHALL CONFORM TO THE REQUIREMENTS OF ASTM A53.
 - D. WELDING SHALL CONFORM TO THE REQUIREMENTS OF THE AMERICAN WELDING SOCIETY'S SPECIFICATION FOR THE MATERIAL BEING WELDED.
 - E. WELDING ELECTRODES SHALL BE E70XX.
2. FINISH
 - A. COMPONENTS SHALL BE COATED WITH POLYESTER TGIC POWDER COAT FINISH MEETING AAMA 2604-02 SPECIFICATION.

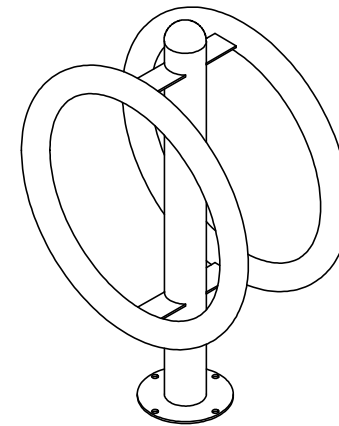

PATTERSON WILLIAMS MFG. CO. P.O. BOX 1290 - SALEM, IL 62881 (800) 851-0865 - www.pwathletic.com			
TITLE ROUND-UP BOLLARD BIKE RACK			
SIZE	DATE	MODEL NO	REV
A	4/24/2013	1701 - 1702 - 1703	
SCALE: 1/2" = 1'-0"		DRAWN: AY	SHEET 1 of 1

8 7 6 5 4 3 2 1