

ADJUSTABLE OFFSET FOR EXISTING BASKETBALL GOAL

MODEL #8104-10 6' OFFSET FOR 5-9/16" O.D. POST (68LBS)

PACKING SLIP	QTY
6' Offset Assembly for 5-9/16" Post	1
72-1/2" Diagonal Brace	2
HARDWARE KIT	
QTY	
5-9/16" O.D. Half Clamp - Galv.	2
5/16"-16 x 1-1/4" Hex Bolt (tab bolt)	1
5/16"-6 Lock Nut - Nylock	1
5/16" Flat Washer	2
1/2"-13 x 3-1/2" Hex Bolt	8
1/2"-13 Lock Nut - Nylock	8
1/2" Flat Washer	16

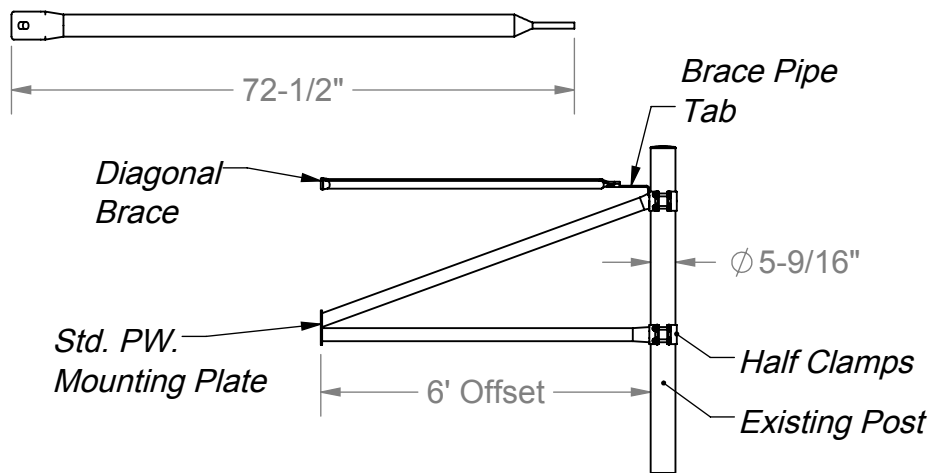

SPECIFICATIONS

A heavy-duty steel adjustable 6-ft offset can be mounted on an existing (customer supplied) straight 5-9/16" O.D. basketball post. Height adjustment of the goal permits regulation play (**10 ft. goal ring height**) providing that the existing post is **12'-6"** minimum height from finish grade to top of post, or use by preschool, elementary school age, physically challenged children or adults.

MATERIAL

Adjustable offset assembly is of welded construction consisting of 2 pieces of 2-3/8" O.D. pipe, (one horizontally & one diagonally), welded to a 1/4" X 6-1/4" x 6-1/2" steel backboard mounting plate at one end and pair of steel half clamps are welded at the opposite end. Heavy-duty 1/4" thick by 3" wide half clamps are formed to fit the diameter of the post and secure the offset to support post with eight (8) 1/2" diameter bolts. To stabilize the backboard a pair of brace pipes, (1 3/8" O.D. Pipe), are mounted between the backboard and the adjustable offset.

Adjustable offset assemblies have welded half clamps formed to fit the diameter of the post. For single offsets use half clamps to attach to post. For Double Offsets, align welded clamps back-to-back & attach.

1. Align clamps back-to-back around the post at ground level. Use 1/2" x 3-1/2" hex bolts for 5-9/16" post, washers & lock nuts to attach (8 total are provided). Tighten hardware slightly.
2. Slide the offset assembly up the post until the top of the backboard mounting plate(s) is at desired height above finished grade. **NOTE:** Official goal ring height is 10-feet, but height is adjustable to accommodate various age groups & physically challenged children & adults.
3. Set the top edge of the backboard mounting plates 1/2" above the goal ring height desired. Align offsets with court(s). Tighten clamp bolts securely.

NOTE: When raising the backboard & goal, assemble using six (6) 3/8" diameter hex bolts. (Recommended). Length of bolts will depend on the style of the backboard used.



Date: 2/17/2015
Rev: 11/21/16
Drawn: MT
Sheet: 1 of 1

SPECIFICATION/INSTALLATION INSTRUCTIONS

ADJUSTABLE OFFSET FOR
EXISTING BASKETBALL POST

MODEL NO.

8104-10 Adjustable Offset